



**Light Commercial Air  
Conditioner  
R410A ON/OFF**

**Service Manual**

A solid blue horizontal bar at the bottom of the page.

# Content

|  |           |
|--|-----------|
| <b>Part 1 General Information .....</b>            | <b>4</b>  |
| 1. Model Names of Indoor/Outdoor Units.....        | 4         |
| 2.External Appearance.....                         | 5         |
| <b>Part 2 Indoor Units .....</b>                   | <b>7</b>  |
| <b>Cassette Type .....</b>                         | <b>7</b>  |
| 1. Features .....                                  | 7         |
| 2. Specifications .....                            | 10        |
| 3. Dimensions.....                                 | 14        |
| 4. Service Space .....                             | 16        |
| 5. Wiring Diagram .....                            | 18        |
| 6. Air Velocity and Temperature Distributions..... | 21        |
| 7. Electric Characteristics.....                   | 22        |
| 8. Sound Levels.....                               | 23        |
| 9. The Specification of Wiring.....                | 24        |
| <b>MSP Duct Type .....</b>                         | <b>25</b> |
| 1. Features .....                                  | 25        |
| 2. Specifications .....                            | 27        |
| 3. Dimensions.....                                 | 32        |
| 4. Service Space .....                             | 33        |
| 5. Wiring Diagrams.....                            | 34        |
| 6. Electric Characteristics.....                   | 37        |
| 7. Sound levels .....                              | 38        |
| 8. The Specification of Wiring.....                | 39        |
| <b>Ceiling &amp; Floor Type .....</b>              | <b>40</b> |
| 1. Features .....                                  | 40        |
| 2. Specifications .....                            | 42        |
| 3. Dimensions.....                                 | 46        |
| 4. Service Space .....                             | 46        |
| 5. Wiring Diagrams.....                            | 48        |
| 6. Air Velocity and Temperature Distributions..... | 51        |
| 7. Electric Characteristics.....                   | 53        |
| 8. Sound Levels.....                               | 54        |

|   |           |
|---|-----------|
| 9. The Specification of Wiring.....     | 55        |
| <b>Part 3 Outdoor Units.....</b>        | <b>56</b> |
| 1. Specifications .....                 | 56        |
| 2. Service Space .....                  | 61        |
| 3. Wiring Diagrams.....                 | 62        |
| 4. Electric Characteristics.....        | 66        |
| 5. Operation Limits .....               | 67        |
| 6. Sound Levels.....                    | 68        |
| 7. Troubleshooting .....                | 69        |
| <b>Part 4 Installation .....</b>        | <b>78</b> |
| 1. Precaution on Installation.....      | 78        |
| 2. Vacuum Dry and Leakage Checking..... | 80        |
| 3. Additional Refrigerant Charge .....  | 82        |
| 4. Water Drainage .....                 | 83        |
| 5. Insulation Work.....                 | 86        |
| 6. Test Operation.....                  | 88        |
| <b>Part 5 Control .....</b>             | <b>89</b> |
| 1. Wireless remote controller .....     | 89        |
| 2. Wired remote controller .....        | 91        |

# Part 1 General Information

## 1. Model Names of Indoor/Outdoor Units

### 1.1 Indoor Units

R410A (capacity multiplied by 1000Btu/h)

| Type                        | Function            | 18 | 24 | 36 | 48 | 60 |
|-----------------------------|---------------------|----|----|----|----|----|
| Four-way cassette (compact) | Cooling and heating | √  | ×  | ×  | ×  | ×  |
| Eight-way cassette          | Cooling and heating | √  | √  | √  | √  | √  |
| Ceiling & floor             | Cooling and heating | √  | √  | √  | √  | √  |
| MSP Duct                    | Cooling and heating | √  | √  | √  | √  | √  |

### 1.2 Outdoor Units

Model of outdoor unit and corresponding indoor unit.

| Universal Outdoor unit Model   | Compressor type | Compressor Brand | Matched indoor units   |
|--|-----------------|------------------|--|
| IQ-H12CA-1/T-O<br>IQ-H12UC-1/T-O<br>IQ-H18CA-1/T-O<br>IQ-H18HD-1/T-O<br>IQ-H18UC-1/T-O | Rotary          | HIGHLY           | IQ-H12CA-1/T-I<br>IQ-H12UC-1/T-I<br>IQ-H18CA-1/T-I(Q4)<br>IQ-H18CA-1/T-I<br>IQ-H18HD-1/T-I<br>IQ-H18UC-1/T-I |
| IQ-H24CA-1/T-O<br>IQ-H24HD-1/T-O<br>IQ-H24UC-1/T-O                                     | Rotary          | HIGHLY           | IQ-H24CA-1/T-I<br>IQ-H24HD-1/T-I<br>IQ-H24UC-1/T-I   |
| IQ-H36CA-1/T-O<br>IQ-H36HD-1/T-O<br>IQ-H36UC-1/T-O                                     | Scroll          | HIGHLY           | IQ-H36CA-1/T-I<br>IQ-H36HD-1/T-I<br>IQ-H36UC-1/T-I   |
| IQ-H36CA-3/T-O<br>IQ-H36HD-3/T-O<br>IQ-H36UC-3/T-O                                     | Rotary          | HIGHLY           | IQ-H36CA-3/T-I<br>IQ-H36HD-3/T-I<br>IQ-H36UC-3/T-I   |
| IQ-H48CA-3/T-O<br>IQ-H48HD-3/T-O<br>IQ-H48UC-3/T-O                                     | Rotary          | HIGHLY           | IQ-H48CA-3/T-I<br>IQ-H48HD-3/T-I<br>IQ-H48UC-3/T-I   |
| IQ-H60CA-3/T-O<br>IQ-H60HD-3/T-O<br>IQ-H60UC-3/T-O                                     | Rotary          | HIGHLY           | IQ-H60CA-3/T-I<br>IQ-H60HD-3/T-I<br>IQ-H60UC-3/T-I   |

# 2.External Appearance

## 2.1 Indoor Units

Four-way Cassette (Compact)



Eight-way Cassette



Duct



Ceiling & floor



## 2.2 Outdoor Units

**18K**



**24K**



**36K**



**48K 60K**



# Part 2 Indoor Units

## Cassette Type

### 1. Features

#### (1) Compact design

Adopts compact design, easy installation by taking off ceiling panel of  $650 \times 650$  or  $950 \times 950$  size.



#### (2) New model design

The newly designed cassette type, featured with 8-way air-out directions, deliver you more comfortable feeling of air.



#### (3) Different swing angel design

Differential swing angels for cooling mode, heating mode and auto swing mode, to ensure comfortable feeling in anytime and anywhere.

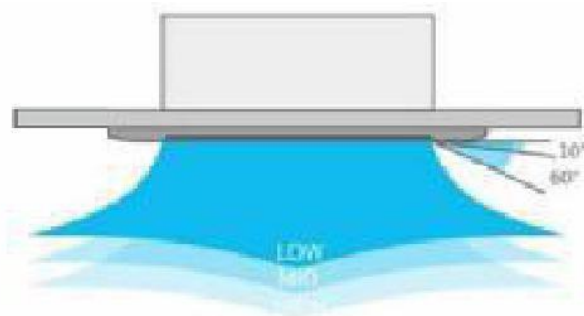

#### (4) Push-open grill easy cleaning of filter

The air intake grill can be easily disassembled by just push-open action, and can be still attached to be the unit by 90 degree rotate angle, designed for easy maintenance and filter cleaning.



(5) Quiet operation

Adopting of advanced 3D centrifugal fan, the units can run more quietly.



(6) Detachable corner panel

Four detachable grille corners enable easy adjustment of hanger positions after installation.



(7) Built-in head drain pump

Standard built-in drain pumps with head height up to 750m m, creating an ideal solution for water drainage.



(8) Anti-cold blowing function

When cooling in winter time, the indoor blower only starts when the indoor coil reaching a coil reaching a certain temp. In order to make sure the blowing air is warm.

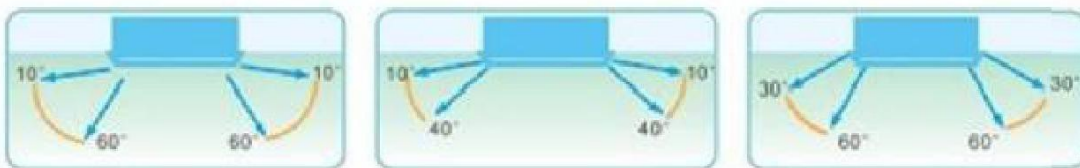

(9) Standard for wireless controller; option for wired controller



## 2. Specifications

| Model name                    | Cassette Indoor              |             | IQ-H18CA-1/T-I (Q4)      | IQ-H18CA-1/T-I           | IQ-H24CA-1/T-I           | IQ-H36CA-1/T-I           |
|-------------------------------|------------------------------|-------------|--------------------------|--------------------------|--------------------------|--------------------------|
| Power supply                  | V//Hz/Ph                     |             | 220-240V~/50Hz/1P        | 220-240V~/50Hz/1P        | 220-240V~/50Hz/1P        | 220-240V~/50Hz/1P        |
| Cooling                       | Capacity                     | Btu/h       | 18000                    | 18000                    | 24000                    | 36000                    |
|                               | Capacity                     | W           | 5175                     | 5200                     | 7000                     | 10500                    |
|                               | Input                        | W           | 1683                     | 1732                     | 2050                     | 3850                     |
|                               | Rated current                | A           | 7.65                     | 7.87                     | 8.70                     | 17.00                    |
|                               | EER                          | W/W         | 3.07                     | 3.00                     | 3.41                     | 2.73                     |
| Heating                       | Capacity                     | Btu/h       | 18000                    | 18000                    | 24000                    | 40000                    |
|                               | Capacity                     | W           | 5200                     | 5200                     | 7000                     | 12000                    |
|                               | Input                        | W           | 1761                     | 1671                     | 1850                     | 3650                     |
|                               | Rated current                | A           | 8.00                     | 8.60                     | 8.0                      | 16.50                    |
|                               | COP                          | W/W         | 3.18                     | 3.53                     | 3.78                     | 3.29                     |
| Indoor coil                   | Number of row                |             | 2                        | 2                        | 2                        | 2                        |
|                               | Fin spacing                  | mm          | 1.6                      | 1.4                      | 1.4                      | 1.4                      |
|                               | Fin material                 |             | Hydrophilic & Louver Fin | Hydrophilic & Louver Fin | Hydrophilic & Louver Fin | Hydrophilic & Louver Fin |
|                               | Tube outside diameter        | mm          | φ7                       | φ7                       | φ7                       | φ7                       |
|                               | Tube material                |             | Innergroover tube type   | Innergroover tube type   | Innergroover tube type   | Innergroover tube type   |
|                               | Coil length x height x width | mm          | 1370×210×25.4            | 1899×168×25.4            | 1899×168×25.4            | 2040×210×25.4            |
|                               | Number of circuit            |             | 5                        | 6                        | 6                        | 9                        |
| Indoor fan motor              | Brand                        |             | lifeng                   | lifeng                   | lifeng                   | lifeng                   |
|                               | Model                        |             | YDK30-6C                 | YDK54-6-1                | YDK55-6-3                | YDK56-6-4                |
|                               | Input                        | W           | 36/30/25                 | 84/62/38                 | 130/108/43               | 148/123/54               |
|                               | Running current              | A           | 0.19/0.15/0.12           | 0.38/0.29/0.18           | 0.60/0.49/0.21           | 0.68/0.58/0.28           |
|                               | Capacitor                    | mF          | 2.0                      | 2..5                     | 3.5                      | 3.5                      |
|                               | Speed (Hi/Me/Lo)             | rpm         | 810/740/655              | 500/420/315              | 700/615/330              | 700/600/340              |
| Indoor air flow (Hi/Me/Lo)    | m <sup>3</sup> /h            | 720/680/600 | 1100/950/880             | 1250/1100/950            | 1600/1500/1400           |                          |
| Indoor noise level (Hi/Me/Lo) | dB(A)                        | 41/38/34    | 42/39/35                 | 43/41/37                 | 45/43/41                 |                          |
| Indoor dimension              | Unit (WxHxD)                 | mm          | 575×260×575              | 830x230x830              | 830x230x830              | 840x245x840              |

|                              |                 |    |                |                |                |                |
|------------------------------|-----------------|----|----------------|----------------|----------------|----------------|
|                              | Packing (WxHxD) | mm | 725×300×725    | 925x290x925    | 925x290x925    | 935x305x935    |
| Indoor weight                | Net             | kg | 19             | 22             | 22             | 26             |
|                              | Gross           | kg | 22             | 27             | 27             | 30             |
| Panel                        | Unit (WxHxD)    | mm | 650×30×650     | 950x45x950     | 950x45x950     | 950x45x950     |
|                              | Packing (WxHxD) | mm | 690×65×690     | 1035×80×1035   | 1035×80×1035   | 1035×80×1035   |
|                              | Net/Gross       | kg | 2.5/4.5        | 6/9            | 6/9            | 6/9            |
| Refrigerant                  | Type            |    | R410A          | R410A          | R410A          | R410A          |
| Refrigerant pipe             | Liquid side     | mm | 6.35           | 6.35           | 9.52           | 9.52           |
|                              | Gas side        | mm | 12.70          | 12.70          | 15.88          | 15.88          |
| Drainage water pipe diameter |                 | mm | OD32           | OD32           | OD32           | OD32           |
| Ambient temperature range    | Cooling         | °C | 21 ~ 43        | 21 ~ 43        | 21 ~ 43        | 21 ~ 43        |
|                              | Heating         | °C | -7 ~ 24        | -7 ~ 24        | -7 ~ 24        | -7 ~ 24        |
| Operation Control            |                 |    | Remote control | Remote control | Remote control | Remote control |

| Model name   | Cassette Indoor       |          | IQ-H36CA-3/T-I           | IQ-H48CA-3/T-I           | IQ-H60CA-3/T-I           |
|--------------|-----------------------|----------|--------------------------|--------------------------|--------------------------|
| Power supply |                       | V//Hz/Ph | 220-240V~/50Hz/1P        | 220-240V~/50Hz/1P        | 220-240V~/50Hz/1P        |
| Cooling      | Capacity              | Btu/h    | 36000                    | 48000                    | 55000                    |
|              | Capacity              | W        | 10500                    | 14000                    | 16119                    |
|              | Input                 | W        | 3723                     | 4636                     | 5694                     |
|              | Rated current         | A        | 7.80                     | 9.30                     | 11.00                    |
|              | EER                   | W/W      | 2.82                     | 3.02                     | 2.83                     |
| Heating      | Capacity              | Btu/h    | 40000                    | 50000                    | 60500                    |
|              | Capacity              | W        | 12000                    | 14650                    | 17731                    |
|              | Input                 | W        | 3409                     | 5079                     | 5700                     |
|              | Rated current         | A        | 7.20                     | 9.50                     | 11.30                    |
|              | COP                   | W/W      | 3.52                     | 2.88                     | 3.11                     |
| Indoor coil  | Number of row         |          | 2                        | 2                        | 2                        |
|              | Fin spacing           | mm       | 1.4                      | 1.5                      | 1.5                      |
|              | Fin material          |          | Hydrophilic & Louver Fin | Hydrophilic & Louver Fin | Hydrophilic & Louver Fin |
|              | Tube outside diameter | mm       | φ7                       | φ7                       | φ7                       |
|              | Tube material         |          | Innergroover tube type   | Innergroover tube type   | Innergroover tube type   |

|                               |                              |                   |                |                |                   |
|-------------------------------|------------------------------|-------------------|----------------|----------------|-------------------|
|                               | Coil length x height x width | mm                | 2040×210×25.4  | 1899×252×25.4  | 1899×252×25.4     |
|                               | Number of circuit            |                   | 9              | 12             | 12                |
| Indoor fan motor              | Brand                        |                   | lifeng         | lifeng         | lifeng            |
|                               | Model                        |                   | YDK56-6-4      | YDK56-6-4      | YDK-75N-6         |
|                               | Input                        | W                 | 148/123/54     | 148/123/54     | 180/150/129       |
|                               | Running current              | A                 | 0.68/0.58/0.28 | 0.68/0.58/0.28 | 0.844/0.684/0.586 |
|                               | Capacitor                    | mF                | 3.5            | 3.5            | 3.5               |
|                               | Speed (Hi/Me/Lo)             | rpm               | 700/600/340    | 700/600/340    | 760/660/560       |
| Indoor air flow (Hi/Me/Lo)    |                              | m <sup>3</sup> /h | 1600/1500/1400 | 1700/1500/1400 | 1900/1700/1500    |
| Indoor noise level (Hi/Me/Lo) |                              | dB(A)             | 45/43/41       | 45/43/41       | 47/44/43          |
| Indoor dimension              | Unit (WxHxD)                 | mm                | 840x245x840    | 830x290x830    | 830x290x830       |
|                               | Packing (WxHxD)              | mm                | 935x305x935    | 925x360x925    | 925x360x925       |
| Indoor weight                 | Net                          | kg                | 26             | 28             | 28                |
|                               | Gross                        | kg                | 30             | 33             | 33                |
| Panel                         | Unit (WxHxD)                 | mm                | 950x45x950     | 950x45x950     | 950x45x950        |
|                               | Packing (WxHxD)              | mm                | 1035×80×1035   | 1035×80×1035   | 1035×80×1035      |
|                               | Net/Gross                    | kg                | 6/9            | 6/9            | 6/9               |
| Refrigerant                   | Type                         |                   | R410A          | R410A          | R410A             |
| Refrigerant pipe              | Liquid side                  | mm                | 9.52           | 9.52           | 9.52              |
|                               | Gas side                     | mm                | 15.88          | 19.05          | 19.05             |
| Drainage water pipe diameter  |                              | mm                | OD32           | OD32           | OD32              |
| Ambient temperature range     | Cooling                      | °C                | 21 ~ 43        | 21 ~ 43        | 21 ~ 43           |
|                               | Heating                      | °C                | -7 ~ 24        | -7 ~ 24        | -7 ~ 24           |
| Operation Control             |                              |                   | Remote control | Remote control | Remote control    |

Notes:

1. Nominal cooling capacities are based on the following conditions: indoor temp: 27°CDB, 19°CWB; Outdoor temp: 35°CDB; Equivalent ref. piping: 7.5m (horizontal)
2. Nominal heating capacities are based on the following conditions: Indoor temp: 20°CDB; Outdoor temp: 7°CDB, 6°CWB; Equivalent ref. piping: 7.5m (horizontal)
3. Actual noise level may differ, depending on the room structure, etc, since these noise values are from an anechoic room.

Remark: The above design and specification are subject to change without prior notice for product improvement.

### 3. Dimensions

IQ-H18CA-1/T-I(Q4)

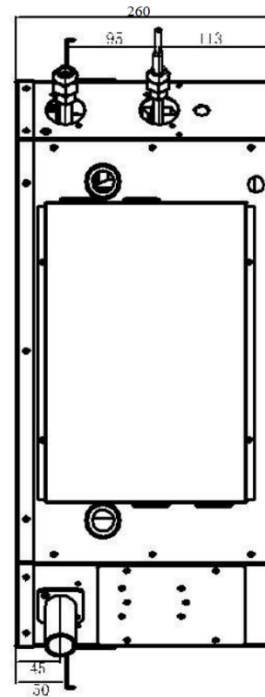
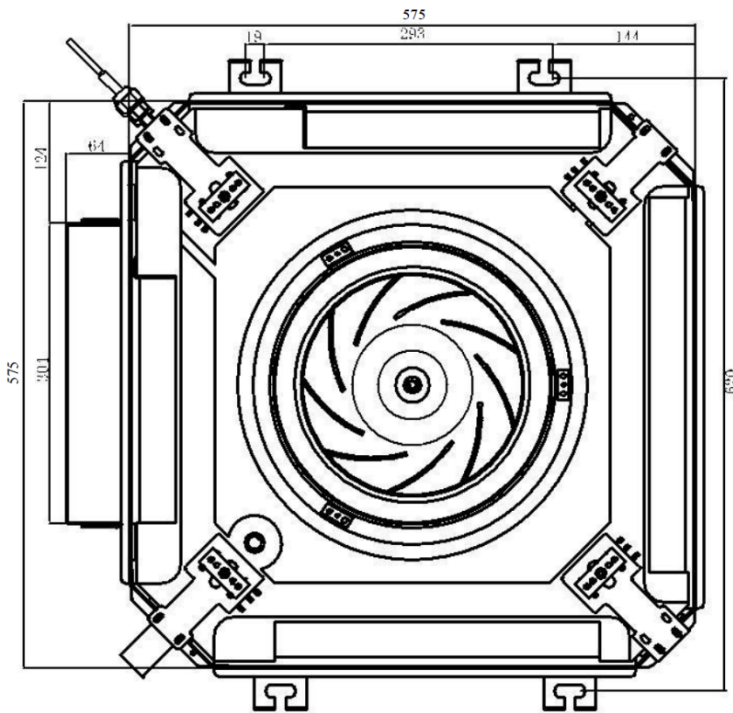

IQ-H18CA-1/T-I & IQ-H24CA-1/T-I

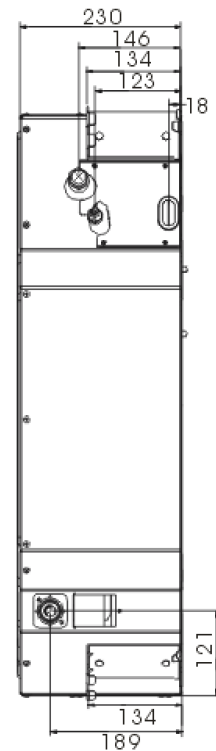
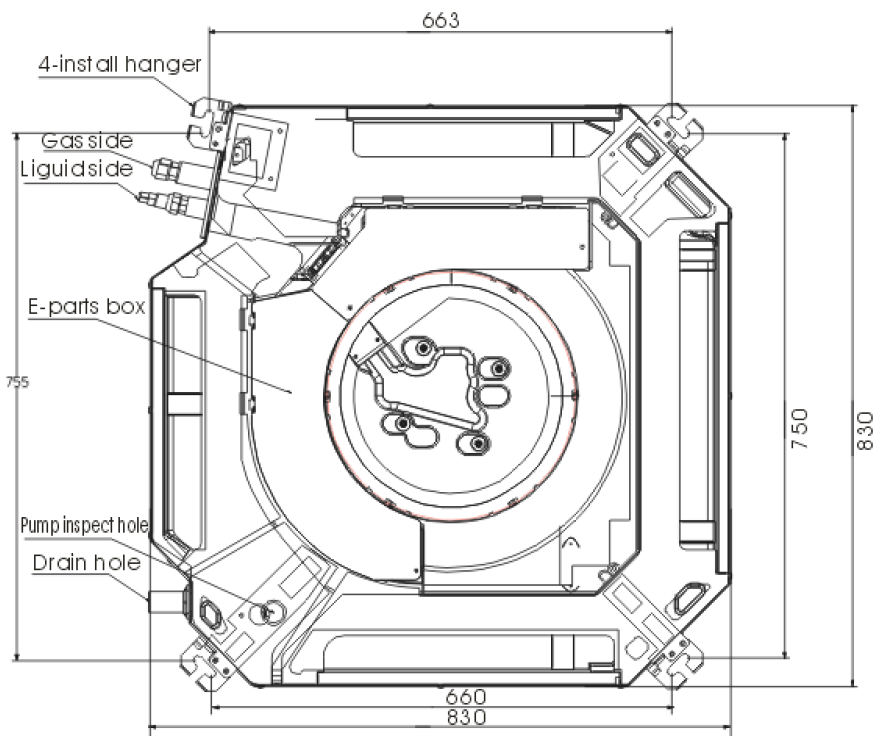

IQ-H36CA-1/T-I & IQ-H36CA-3/T-I

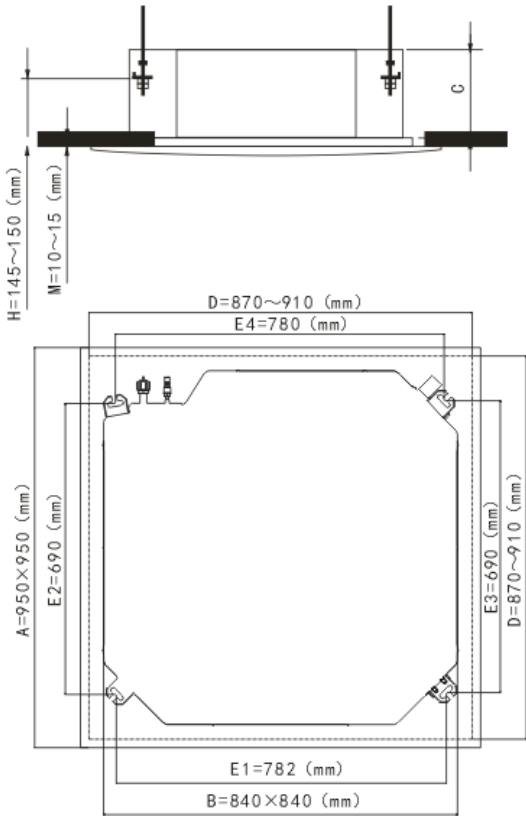

Graphical representation:

- A: Panel size
- B: Dimensions of indoor machine
- C: Height of indoor unit  
(36k is 255mm, 48/60k 300mm)
- D: Ceiling opening size
- E: Indoor machine hook spacing
- H: Distance from hook to bottom of ceiling
- M: Panel seal sponge thickness

IQ-H48CA-3/T-I & IQ-H60CA-3/T-I

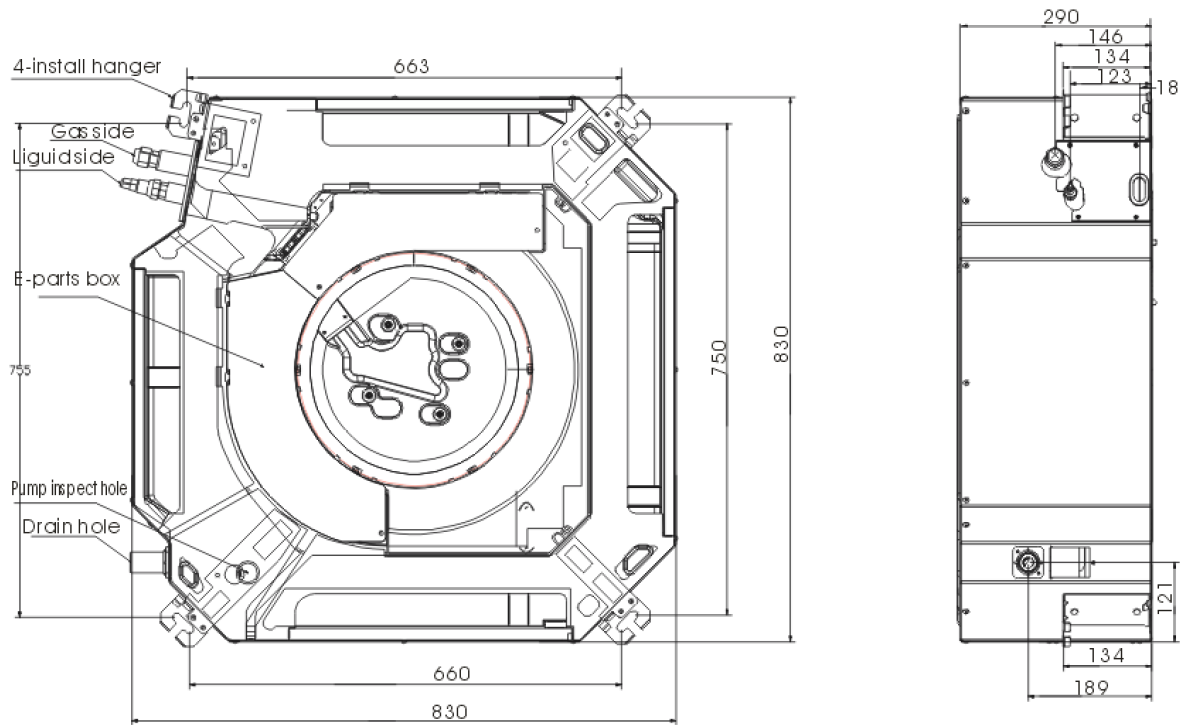

## 4. Service Space

1. Location in the following places may cause malfunction of the machine. (If unavoidable, please consult your local dealer)

- a. A place where there is flammable gas leakage.
- b. There is salty air surrounding (near the coast).
- c. There is caustic gas (the sulfide, for example) existing in the air (near a hot spring).
- d. A place where can not bear the weight of the machine.
- e. In kitchen where it is full of oil gas
- f. There is strong electromagnetic wave existing.
- g. There is acid or alkaline liquid evaporating.
- h. A place where air circulation is not enough.
- I. The appliance shall not be installed in the laundry

2. Electrical Insulation must be done on the air conditioner and the building complying to National Regulations.

3. The installation height between ceiling and floor must be 2.7m~3.2m.

Four-way cassette

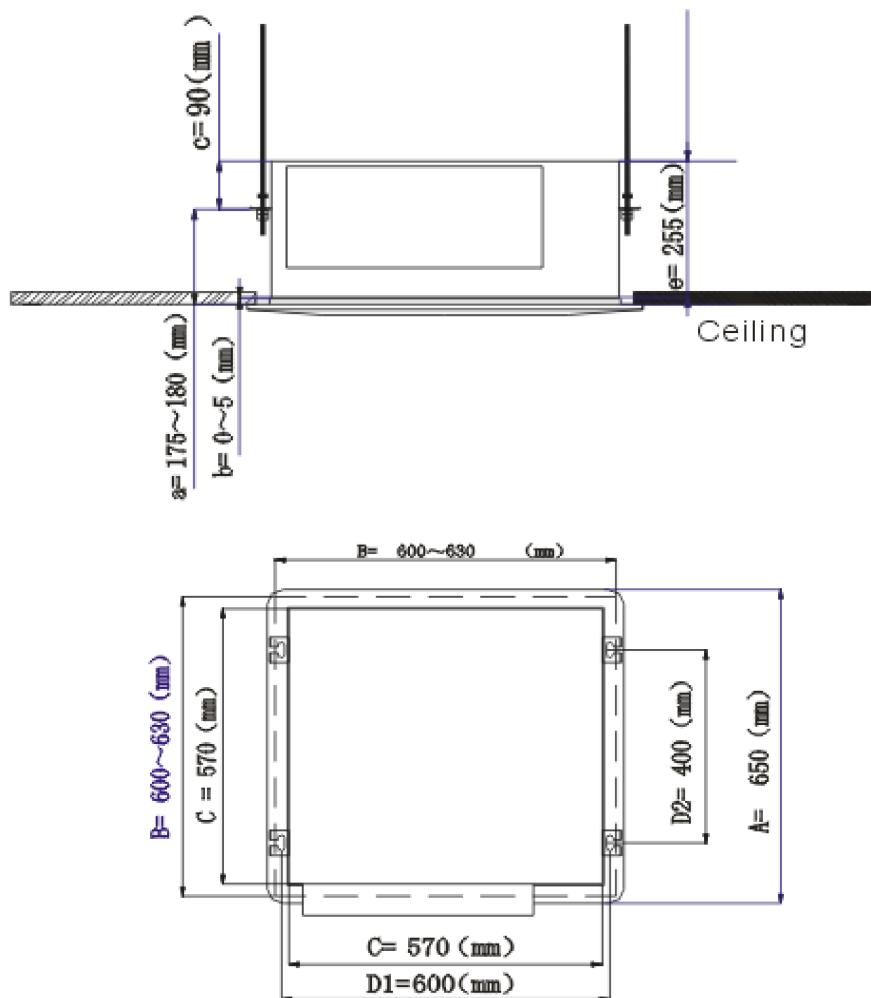

Eight-way cassette

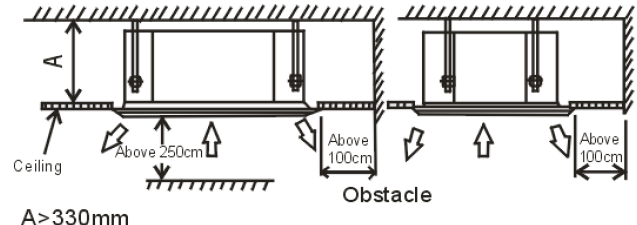

A > 330mm

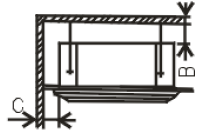

| Wall material | Flammable material | Fire-proof material or other nonflammable materials other than metal | Fire-proof structure |
|---------------|--------------------|--|----------------------|
| Up(B)         | Above 5cm          | Above 5cm  | Above 5cm            |
| Sides(C)      | Above 100cm        | Above 100cm  | —                    |

# 5. Wiring Diagram

## 5.1 IQ-H18CA-1/T-I(Q4) & IQ-H36CA-1/T-I & IQ-H36CA-3/T-I & IQ-H48CA-3/T-I & IQ-H60CA-3/T-I

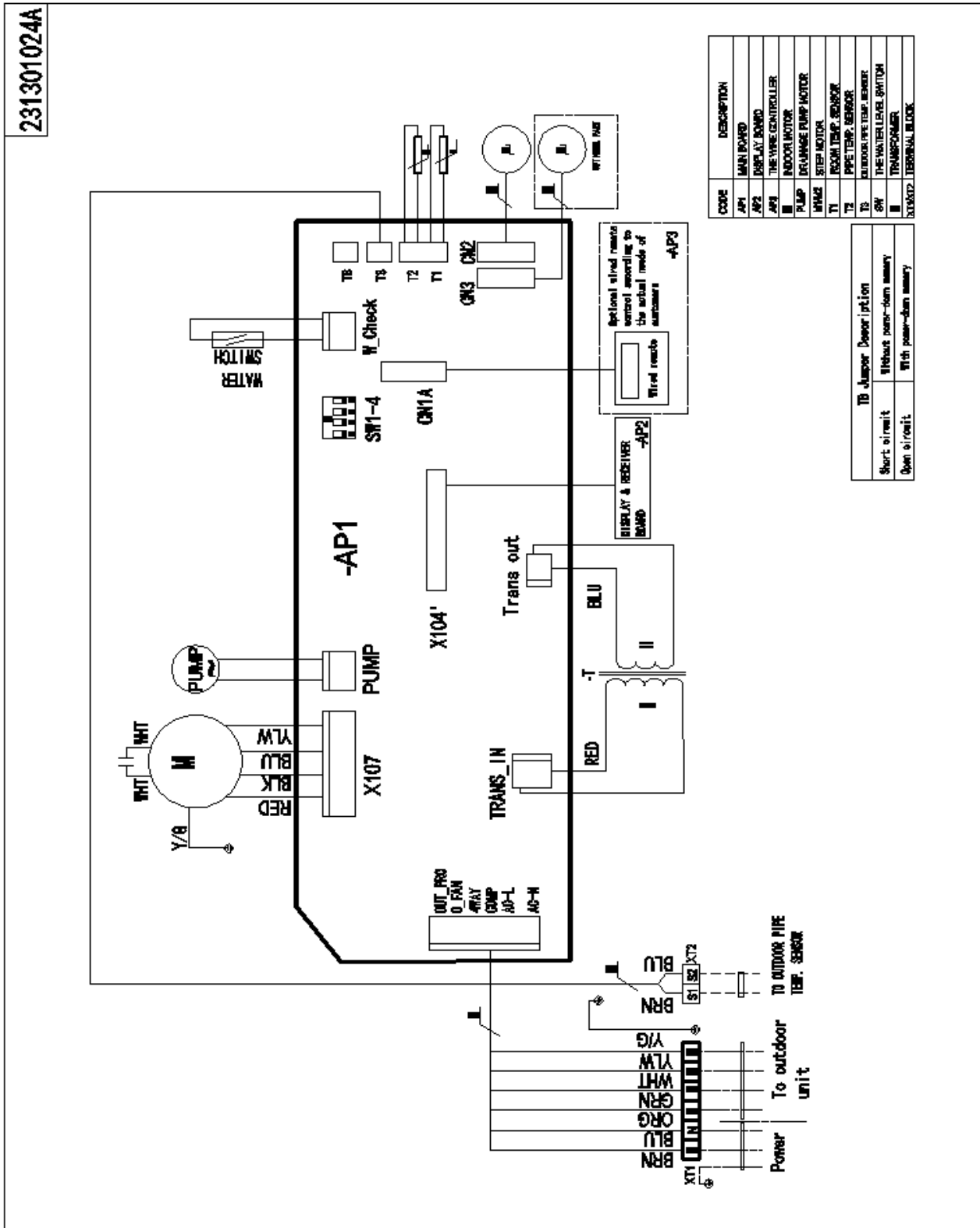

## 5.2 IQ-H12CA-1/T-I ;IQ-H18CA-1/T-I

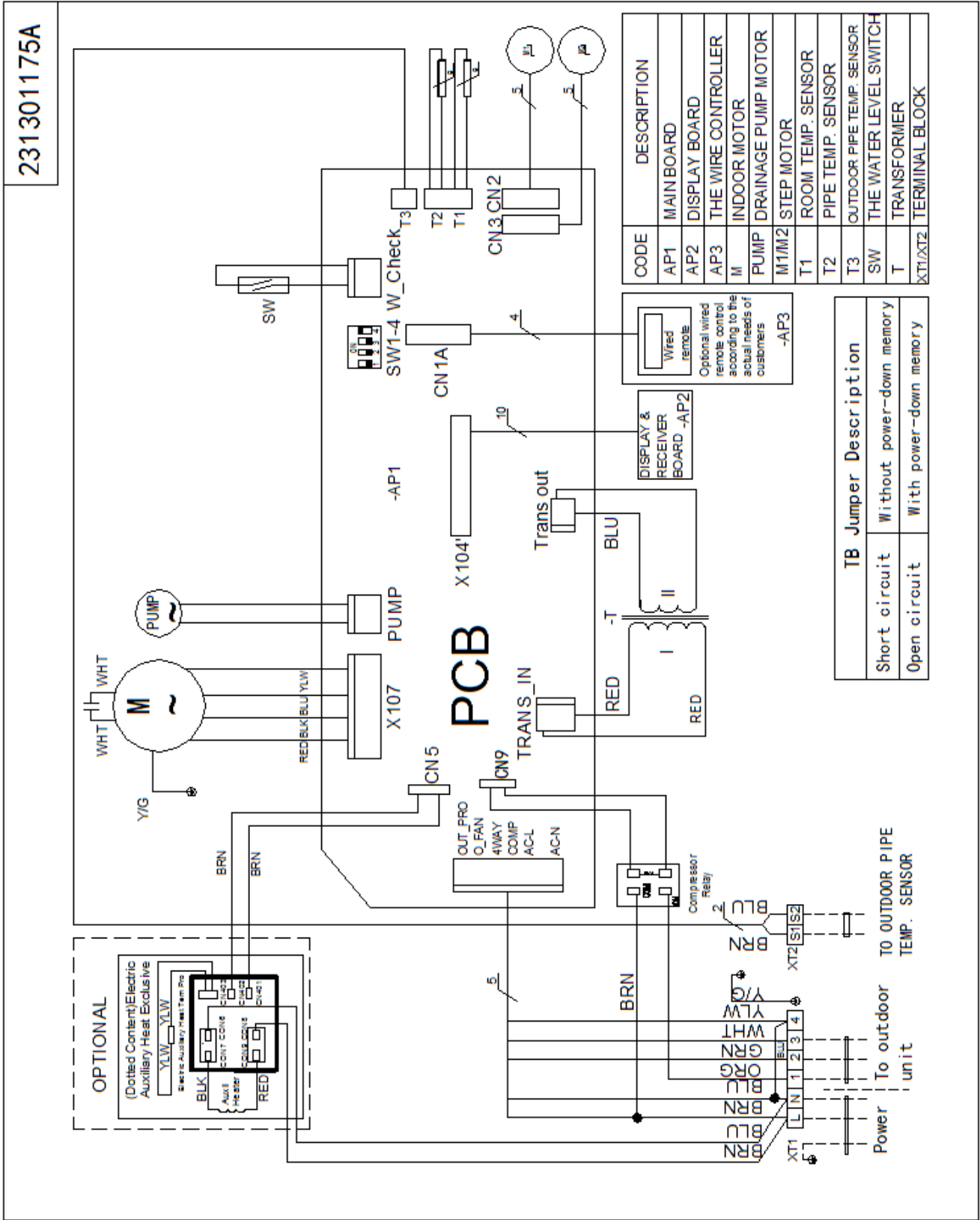

### 5.3 IQ-H24CA-1/T-1

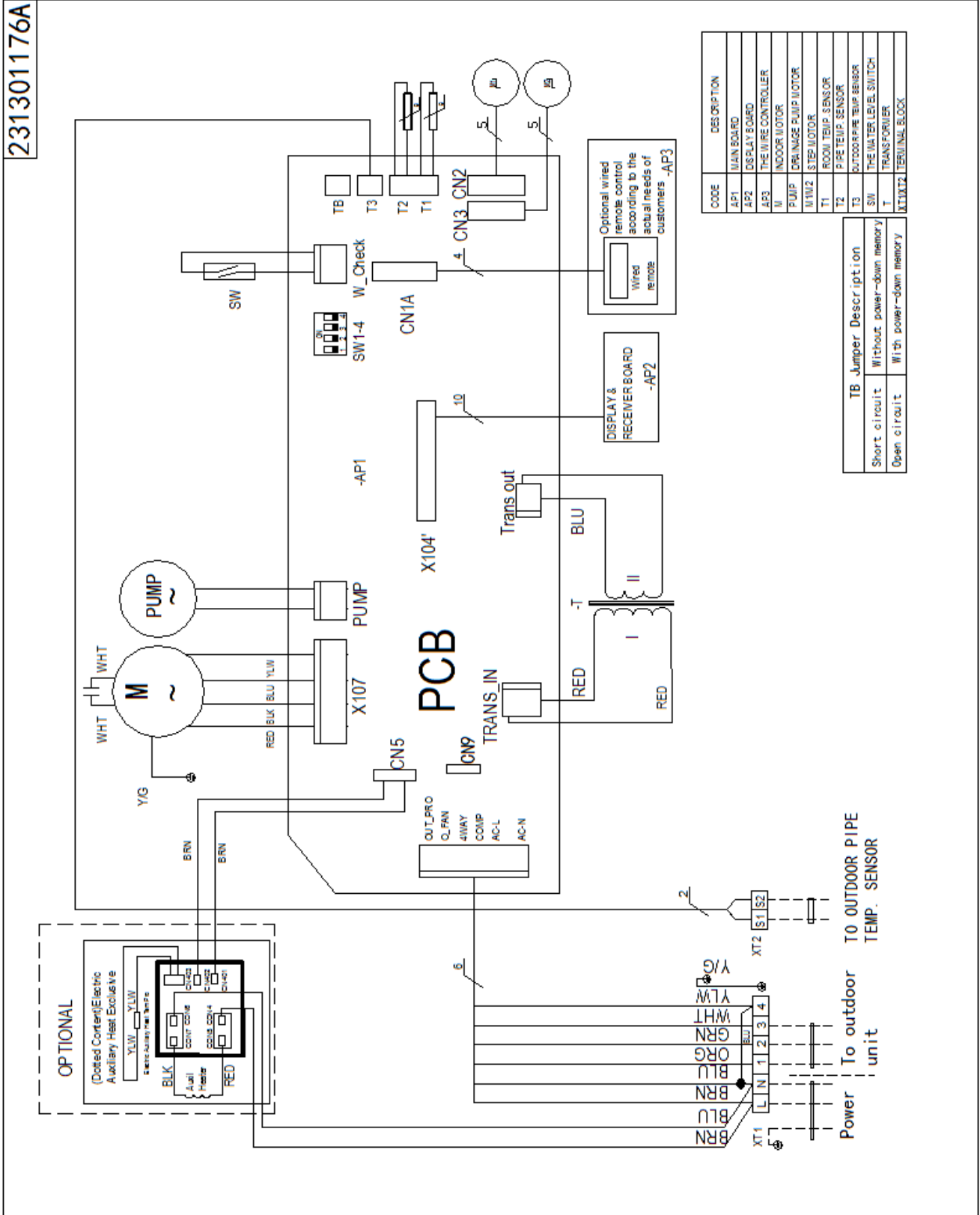

## 6. Air Velocity and Temperature Distributions

Airflow velocity

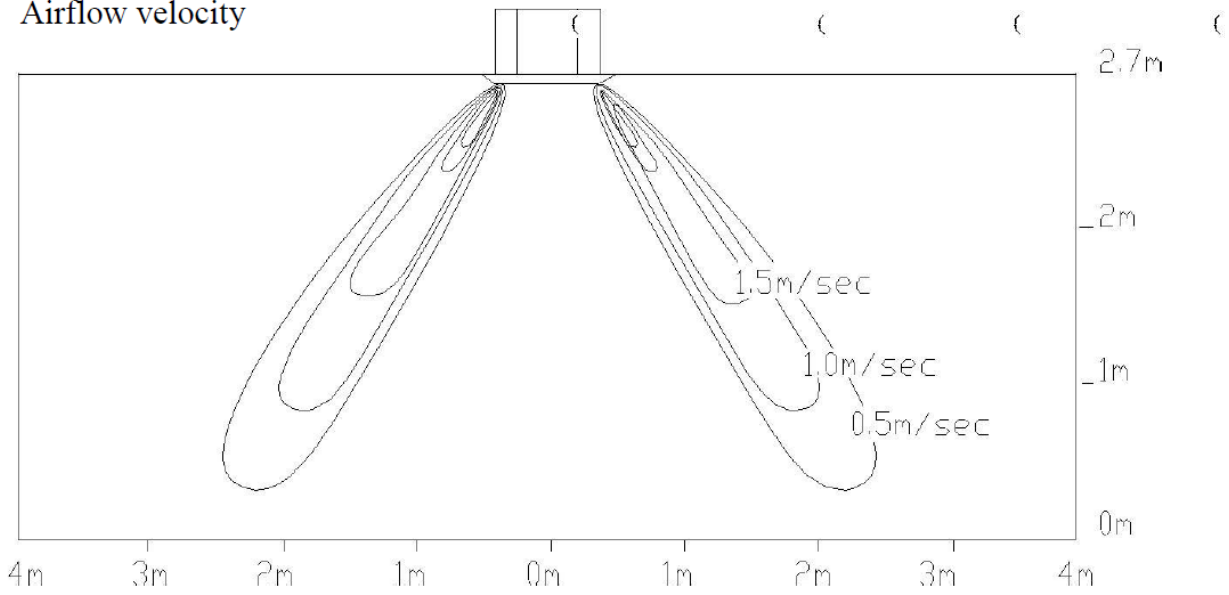

Temperature

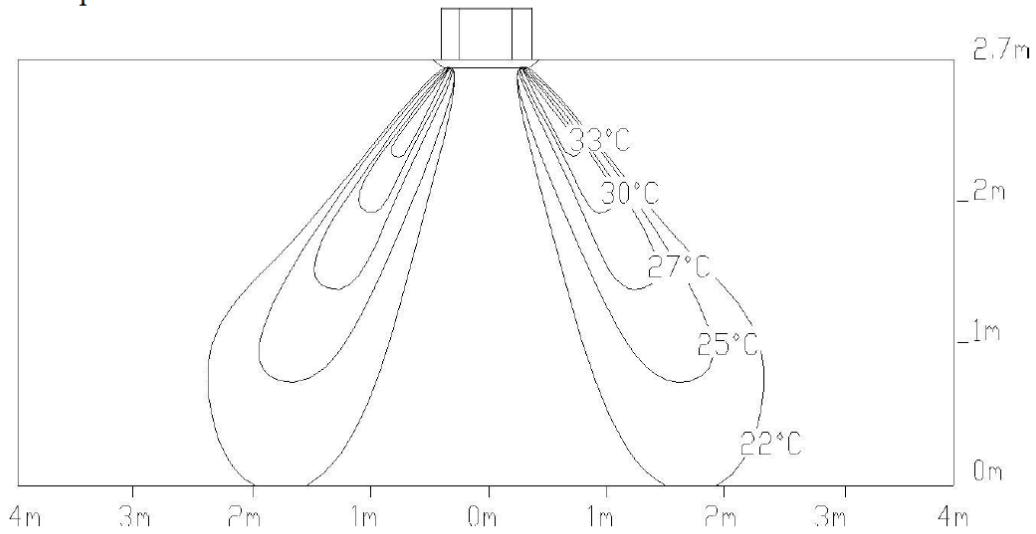

## 7. Electric Characteristics

| Model                            | Indoor units |             |        |         | Indoor Fan Motor |
|----------------------------------|--------------|-------------|--------|---------|------------------|
|                                  | Hz           | Voltage (V) | Min(V) | Max (V) | Kw               |
| IQ-H18CA-1/T-I(Q4)               | 50           | 220-240V    | 198    | 254     | 0.036            |
| IQ-H12CA-1/T-I<br>IQ-H18CA-1/T-I | 50           | 220-240V    | 198    | 254     | 0.084            |
| IQ-H24CA-1/T-I                   | 50           | 220-240V    | 198    | 254     | 0.130            |
| IQ-H36CA-1/T-I                   | 50           | 220-240V    | 198    | 254     | 0.148            |
| IQ-H36CA-3/T-I                   | 50           | 220-240V    | 198    | 254     | 0.148            |
| IQ-H48CA-3/T-I                   | 50           | 220-240V    | 198    | 254     | 0.148            |
| IQ-H60CA-3/T-I                   | 50           | 220-240V    | 198    | 254     | 0.180            |

## 8. Sound Levels

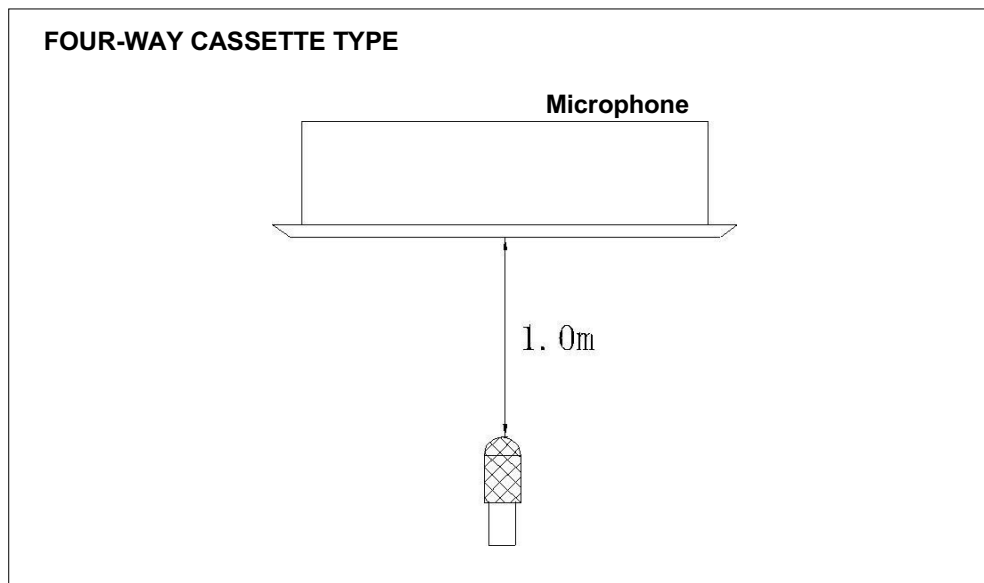

| Model                            | Noise level (dB) |    |    |
|----------------------------------|------------------|----|----|
|                                  | H                | M  | L  |
| IQ-H18CA-1/T-I(Q4)               | 41               | 38 | 34 |
| IQ-H12CA-1/T-I<br>IQ-H18CA-1/T-I | 42               | 39 | 35 |
| IQ-H24CA-1/T-I                   | 43               | 41 | 37 |
| IQ-H36CA-1/T-I                   | 45               | 43 | 41 |
| IQ-H36CA-3/T-I                   | 45               | 43 | 41 |
| IQ-H48CA-3/T-I                   | 45               | 43 | 41 |
| IQ-H60CA-3/T-I                   | 47               | 44 | 43 |

## 9. The Specification of Wiring

| Model                |                               | IQ-H18CA-1/T-I(Q4) | IQ-H12CA-1/T-I; IQ-H18CA-1/T-I | IQ-H24CA-1/T-I                                   | IQ-H36CA-1/T-I |        |
|----------------------|-------------------------------|--------------------|--------------------------------|--|----------------|--------|
| Indoor power supply  | V/Ph/Hz                       | 220~240/1/50       |                                |  |                |        |
| Outdoor power supply | V/Ph/Hz                       | 220~240/1/50       |                                |  |                |        |
| Connection wiring    | Outdoor Power Supply          | From indoor unit   |                                | Power supply individually for indoor and outdoor |                |        |
|                      | Power wiring for indoor unit  | mm <sup>2</sup>    | 3×2.5                          | 3×2.5  | 3×2.5          | 3×2.5  |
|                      | Power wiring for outdoor unit | mm <sup>2</sup>    | /                              | /  | 3×2.5          | 3×2.5  |
|                      | Strong Electric Signal        | mm <sup>2</sup>    | 5×2.5                          | 5×2.5  | 3×2.5          | 4×2.5  |
|                      | Weak Electric Signal          | mm <sup>2</sup>    | 2×0.75                         | 2×0.75   | 2×0.75         | 2×0.75 |

| Model                |                               | IQ-H36CA-3/T-I  | IQ-H48CA-3/T-I                                   | IQ-H60CA-3/T-I |        |
|----------------------|-------------------------------|-----------------|--|----------------|--------|
| Indoor power supply  | V/Ph/Hz                       | 220~240/1/50    |  |                |        |
| Outdoor power supply | V/Ph/Hz                       | 380~415/3/50    |  |                |        |
| Connection wiring    | Outdoor Power Supply          |                 | Power supply individually for indoor and outdoor |                |        |
|                      | Power wiring for indoor unit  | mm <sup>2</sup> | 3×2.5  | 3×2.5          | 3×2.5  |
|                      | Power wiring for outdoor unit | mm <sup>2</sup> | 5×2.5  | 5×2.5          | 5×2.5  |
|                      | Strong Electric Signal        | mm <sup>2</sup> | 4×2.5  | 4×2.5          | 4×2.5  |
|                      | Weak Electric Signal          | mm <sup>2</sup> | 2×0.75   | 2×0.75         | 2×0.75 |

# MSP Duct Type

## 1. Features

(1) Economic and convenient installation

---Several diffusers branch off from an indoor unit, adjusting the room temperature, which makes many rooms to be air-conditioned with only one indoor unit.

---All models feature thin design making them applicable to ceiling pocket that tends to be shallow

(2) Way of air intake and inserting air filter

---Air intake can be positioned either at the back or below the unit. Similarly, the air filter also can be inserted either from the back or from the bottom of the unit.

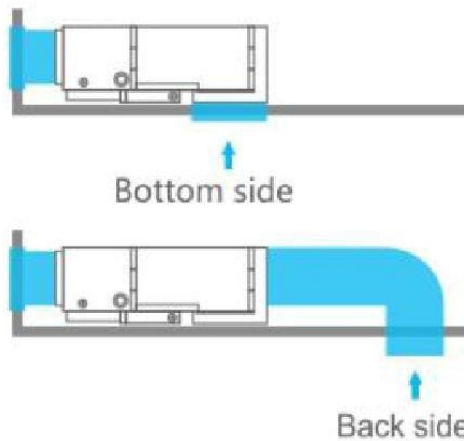

(3) Easy for maintenance

Detachable plastic air blowers, make the maintenance of fan motor more easily.

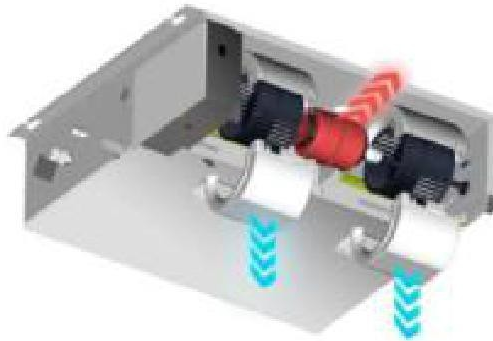

(4) Built-in head drain pump (optional)

Built-in drain pumps with head height up to 750mm, creating an ideal solution for water drainage.

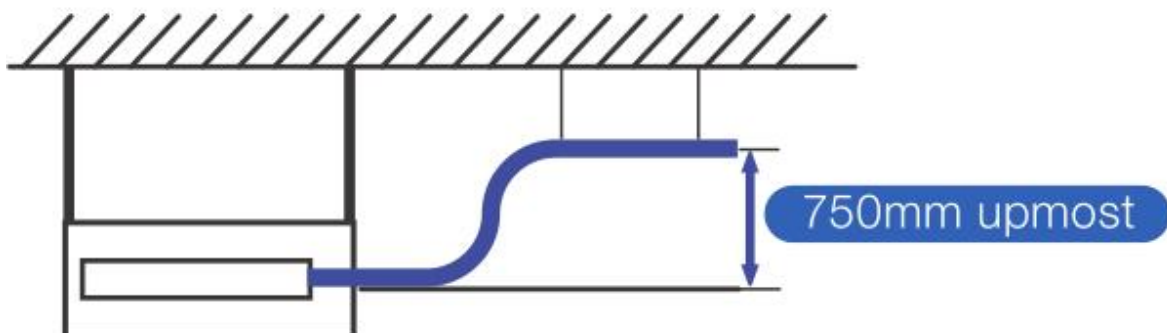

(5) Dual-direction drainage pipe design

The condensing water can be drained from either right or left

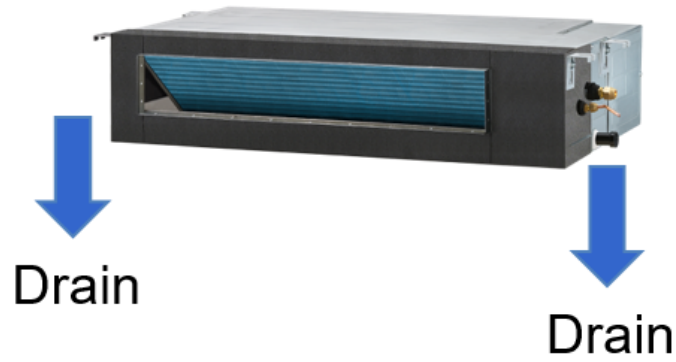

(6) Standard for wireless controller; option for wired controller



## 2. Specifications

| Model name   | MESP Duct Indoor             |          | IQ-H18HD-1/T-I           | IQ-H24HD-1/T-I           | IQ-H36HD-1/T-I           |
|--------------|------------------------------|----------|--------------------------|--------------------------|--------------------------|
| Power supply |                              | V//Hz/Ph | 220-240V~/50Hz/1P        | 220-240V~/50Hz/1P        | 220-240V~/50Hz/1P        |
| Cooling      | Capacity                     | Btu/h    | 18000                    | 24000                    | 36000                    |
|              | Capacity                     | W        | 5200                     | 7000                     | 10500                    |
|              | Input                        | W        | 1761                     | 2050                     | 3850                     |
|              | Rated current                | A        | 8.00                     | 8.70                     | 17.00                    |
|              | EER                          | W/W      | 2.95                     | 3.41                     | 2.73                     |
| Heating      | Capacity                     | Btu/h    | 18000                    | 24000                    | 40000                    |
|              | Capacity                     | W        | 5200                     | 7000                     | 12000                    |
|              | Input                        | W        | 1513                     | 1850                     | 3650                     |
|              | Rated current                | A        | 6.87                     | 8.0                      | 16.50                    |
|              | COP                          | W/W      | 3.90                     | 3.78                     | 3.29                     |
| Indoor coil  | Number of row                |          | 3                        | 3                        | 3                        |
|              | Fin spacing                  | mm       | 1.4                      | 1.4                      | 1.4                      |
|              | Fin material                 |          | Hydrophilic & Louver Fin | Hydrophilic & Louver Fin | Hydrophilic & Louver Fin |
|              | Tube outside diameter        | mm       | φ7                       | φ7                       | φ7                       |
|              | Tube material                |          | Innergroover tube type   | Innergroover tube type   | Innergroover tube type   |
|              | Coil length x height x width | mm       | 734×252×38.1             | 734×252×38.1             | 977×336×38.1             |
|              | Number of circuit            |          | 6                        | 6                        | 8                        |

|                                      |                  |                   |                     |                     |                      |
|--------------------------------------|------------------|-------------------|---------------------|---------------------|----------------------|
| Indoor fan motor                     | Brand            |                   | Match-well          | Match-well          | Match-well           |
|                                      | Model            |                   | YSK68-4P-5          | YSK74-4P-5          | YSK140-4P-5          |
|                                      | Input            | W                 | 98/86/72/66         | 190/136/104/82      | 268/218/156/128      |
|                                      | Running current  | A                 | 0.45/0.48/0.37/0.30 | 0.88/0.63/0.49/0.39 | 1.25/1.00/1.08/0.582 |
|                                      | Capacitor        | uF                | 4                   | 5                   | 10                   |
|                                      | Speed (Hi/Me/Lo) | rpm               | 1140/1000/775/660   | 990/830/720/640     | 1055/920/750/665     |
| Indoor air flow (Hi/Me/Lo)           |                  | m <sup>3</sup> /h | 1170/770/650        | 1400/950/800        | 1800/1500/1350       |
| Indoor external static pressure (Hi) |                  | Pa                | 70                  | 70                  | 80                   |
| Indoor noise level (Hi/Me/Lo)        |                  | dB(A)             | 43/35/32            | 46/43/41            | 46/44/42             |
| Indoor dimension (with filter)       | Unit (WxHxD)     | mm                | 920x210x605         | 920x270x605         | 1140x270x745         |
|                                      | Packing (WxHxD)  | mm                | 1115x280x690        | 1115x340x690        | 1345x345x830         |
| Indoor weight                        | Net              | kg                | 22                  | 28                  | 35                   |
|                                      | Gross            | kg                | 27                  | 32                  | 42                   |
| Refrigerant                          | Type             |                   | R410A               | R410A               | R410A                |
| Refrigerant pipe                     | Liquid side      | mm                | 6.35                | 9.52                | 9.52                 |
|                                      | Gas side         | mm                | 12.70               | 15.88               | 15.88                |
| Drainage water pipe diameter         |                  | mm                | OD25                | OD25                | OD25                 |
| Ambient temperature range            | Cooling          | °C                | 21 ~ 43             | 21 ~ 43             | 21 ~ 43              |
|                                      | Heating          | °C                | -7 ~ 24             | -7 ~ 24             | -7 ~ 24              |
| Operation Control                    |                  |                   | Remote controller   | Remote controller   | Remote controller    |

| Model name       | MESP Duct Indoor             |          | IQ-H36HD-3/T-I           | IQ-H48HD-3/T-I           | IQ-H60HD-3/T-I           |
|------------------|------------------------------|----------|--------------------------|--------------------------|--------------------------|
| Power supply     |                              | V//Hz/Ph | 220-240V~/50Hz/1P        | 220-240V~/50Hz/1P        | 220-240V~/50Hz/1P        |
| Cooling          | Capacity                     | Btu/h    | 36000                    | 48000                    | 55000                    |
|                  | Capacity                     | W        | 10550                    | 14000                    | 16119                    |
|                  | Input                        | W        | 3584                     | 4560                     | 5694                     |
|                  | Rated current                | A        | 7.8                      | 9.30                     | 12.00                    |
|                  | EER                          | W/W      | 2.94                     | 3.07                     | 2.83                     |
| Heating          | Capacity                     | Btu/h    | 40000                    | 50000                    | 60500                    |
|                  | Capacity                     | W        | 12000                    | 14650                    | 17731                    |
|                  | Input                        | W        | 3468                     | 4446                     | 4845                     |
|                  | Rated current                | A        | 7.2                      | 9.50                     | 12.40                    |
|                  | COP                          | W/W      | 3.46                     | 3.30                     | 3.66                     |
| Indoor coil      | Number of row                |          | 3                        | 3                        | 3                        |
|                  | Fin spacing                  | mm       | 1.4                      | 1.4                      | 1.4                      |
|                  | Fin material                 |          | Hydrophilic & Louver Fin | Hydrophilic & Louver Fin | Hydrophilic & Louver Fin |
|                  | Tube outside diameter        | mm       | φ7                       | φ7                       | φ7                       |
|                  | Tube material                |          | Innergroover tube type   | Innergroover tube type   | Innergroover tube type   |
|                  | Coil length x height x width | mm       | 977×336×38.1             | 1030×378×38.1            | 1030×378×38.1            |
|                  | Number of circuit            |          | 8                        | 9                        | 9                        |
| Indoor fan motor | Brand                        |          | Match-well               | Match-well               | Match-well               |

|                                      |                  |                   |                      |                    |                    |
|--------------------------------------|------------------|-------------------|----------------------|--------------------|--------------------|
|                                      | Model            |                   | YSK140-4P-5          | YSK170-4P-2        | YSK170-4P-2        |
|                                      | Input            | W                 | 268/218/156/128      | 326/248/182/138    | 326/248/182/138    |
|                                      | Running current  | A                 | 1.25/1.00/1.08/0.582 | 1.49/1.21/108/0.63 | 1.49/1.21/108/0.63 |
|                                      | Capacitor        | uF                | 10                   | 10                 | 10                 |
|                                      | Speed (Hi/Me/Lo) | rpm               | 1055/920/750/665     | 1060/890/740/630   | 1060/890/740/630   |
| Indoor air flow (Hi/Me/Lo)           |                  | m <sup>3</sup> /h | 1800/1500/1350       | 2100/1750/1550     | 2200/1800/1600     |
| Indoor external static pressure (Hi) |                  | Pa                | 80                   | 100                | 100                |
| Indoor noise level (Hi/Me/Lo)        |                  | dB(A)             | 46/44/42             | 47/44/42           | 47/45/43           |
| Indoor dimension<br>(with filter)    | Unit (WxHxD)     | mm                | 1140x270x745         | 1200x300x835       | 1200x300x835       |
|                                      | Packing (WxHxD)  | mm                | 1345x345x830         | 1405x375x925       | 1405x375x925       |
| Indoor weight                        | Net              | kg                | 35                   | 43                 | 43                 |
|                                      | Gross            | kg                | 42                   | 50                 | 50                 |
| Refrigerant                          | Type             |                   | R410A                | R410A              | R410A              |
| Refrigerant pipe                     | Liquid side      | mm                | 9.52                 | 9.52               | 9.52               |
|                                      | Gas side         | mm                | 15.88                | 19.05              | 19.05              |
| Drainage water pipe diameter         |                  | mm                | OD25                 | OD25               | OD25               |
| Ambient temperature range            | Cooling          | °C                | 21 ~ 43              | 21 ~ 43            | 21 ~ 43            |
|                                      | Heating          | °C                | -7 ~ 24              | -7 ~ 24            | -7 ~ 24            |
| Operation Control                    |                  |                   | Remote controller    | Remote controller  | Remote controller  |

Notes:

1. Nominal cooling capacities are based on the following conditions: indoor temp: 27°CDB, 19°CWB; Outdoor temp: 35°CDB; Equivalent ref. piping: 7.5m (horizontal)
2. Nominal heating capacities are based on the following conditions: Indoor temp: 20°CDB; Outdoor temp: 7°CDB, 6°CWB; Equivalent ref. piping: 7.5m (horizontal)
3. Actual noise level may differ, depending on the room structure, etc, since these noise values are from an anechoic room.

Remark: The above design and specification are subject to change without prior notice for product improvement.

### 3. Dimensions

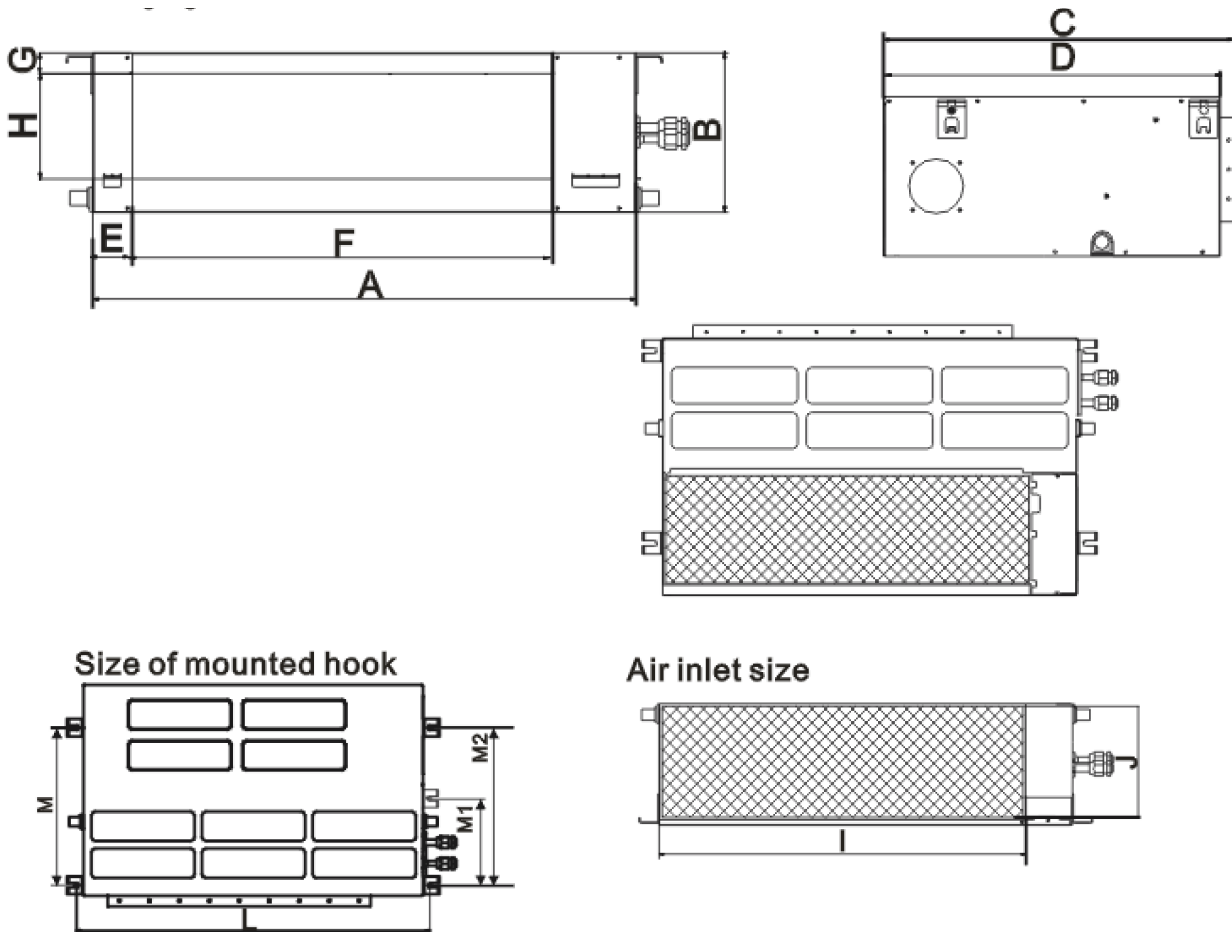

|       | Outline dimension |     |     |     | Air outlet opening size |     |    |     | Air return opening size |     |    | Size of mounted lug |     |     |     |
|-------|-------------------|-----|-----|-----|-------------------------|-----|----|-----|-------------------------|-----|----|---------------------|-----|-----|-----|
|       | A                 | B   | C   | D   | E                       | F   | G  | H   | I                       | J   | K  | L                   | M   | M1  | M2  |
| 18    | 920               | 210 | 635 | 570 | 65                      | 713 | 35 | 119 | 815                     | 200 | 80 | 958                 | 427 | 240 | /   |
| 24    | 920               | 270 | 635 | 570 | 65                      | 713 | 35 | 179 | 815                     | 260 | 20 | 958                 | 427 | /   | 427 |
| 36    | 1140              | 270 | 775 | 710 | 65                      | 933 | 35 | 179 | 1035                    | 260 | 45 | 1184                | 541 | /   | 541 |
| 48/60 | 1200              | 300 | 865 | 800 | 80                      | 968 | 40 | 204 | 1094                    | 268 | 45 | 1238                | 585 | /   | 585 |

---

## 4. Service Space

Ensure enough space required for installation and maintenance.

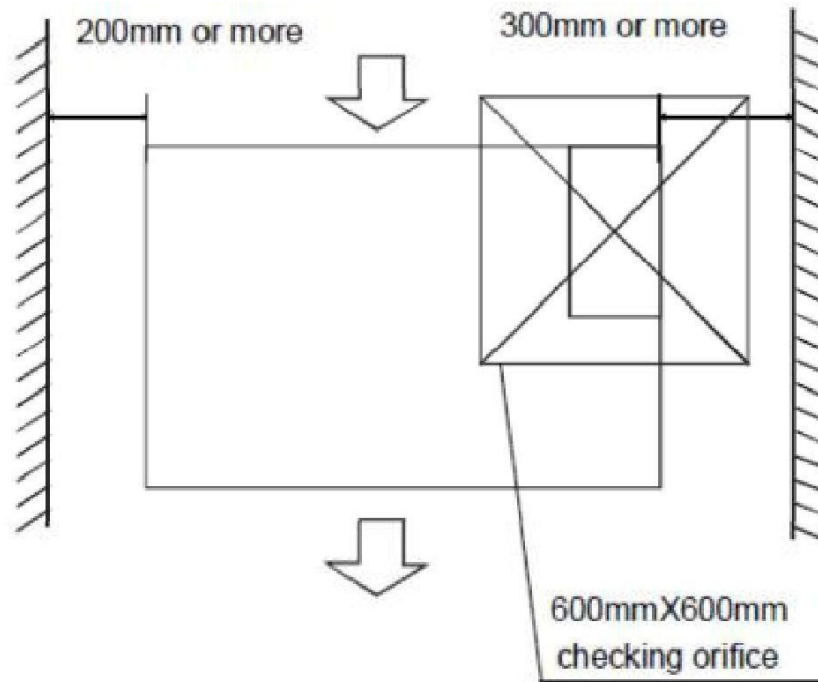

There is enough space for installation and maintenance. The ceiling is horizontal, and its structure can endure the weight of the indoor unit. The outlet and the inlet are not impeded, and the influence of external air is the least. The air flow can reach throughout the room. The connecting pipe and drainpipe could be extracted out easily. There is no direct radiation from heater.

# 5. Wiring Diagrams

## 5.1 IQ-H18HD-1/T-I

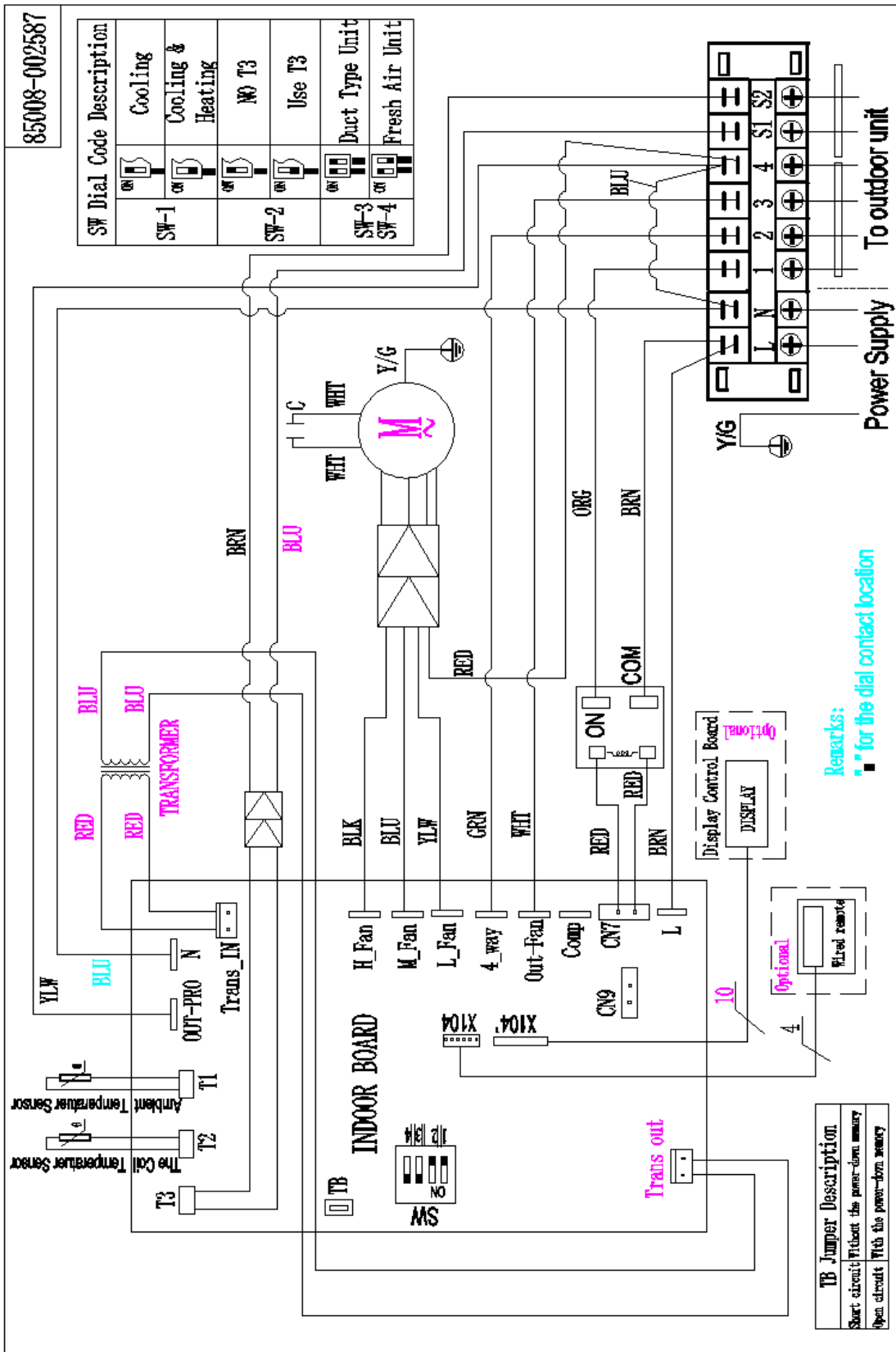

## 5.2 IQ-H24HD-1/T-I

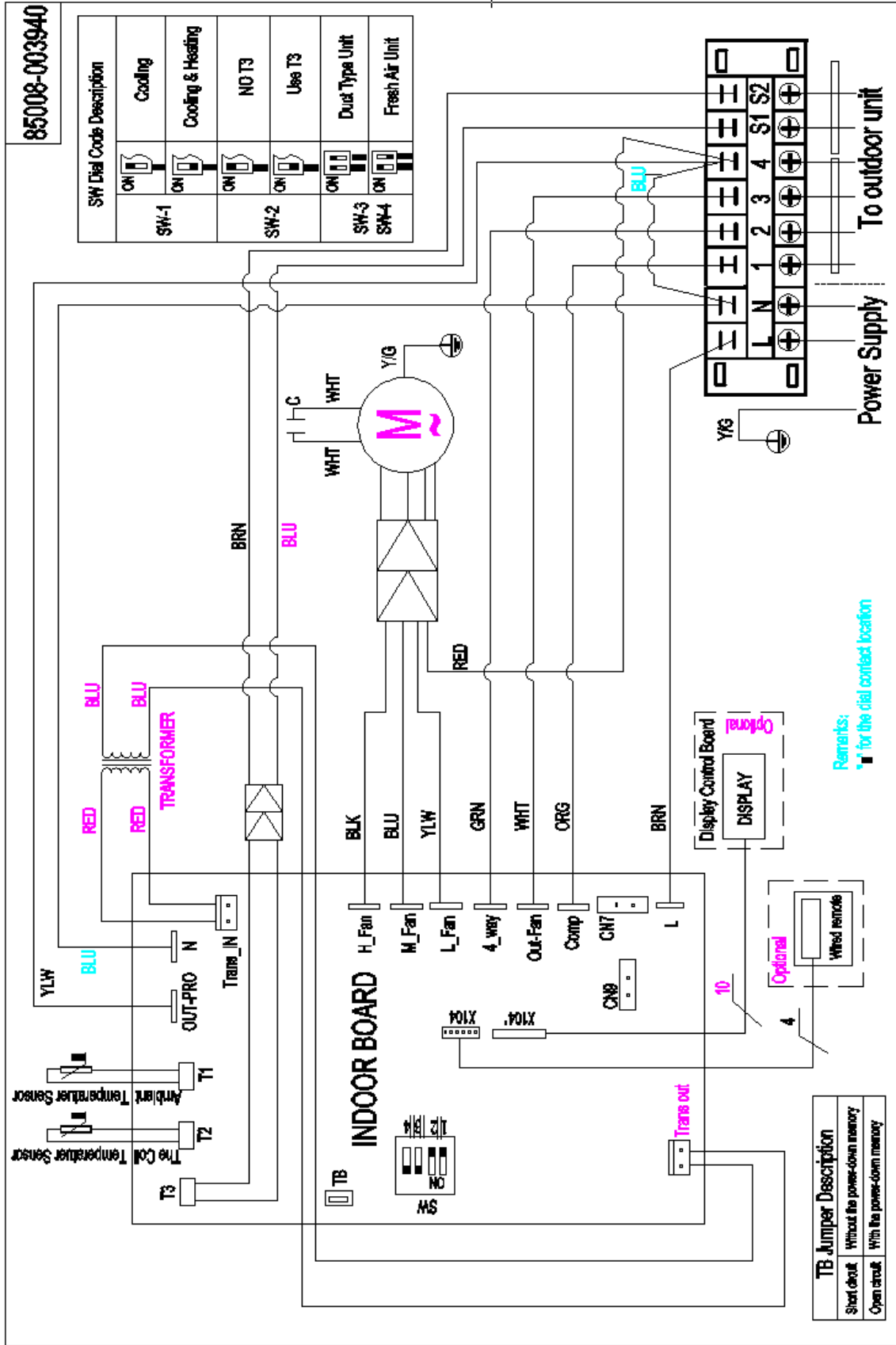



## 6. Electric Characteristics

| Model          | Indoor units |             |         |        | Indoor Fan Motor |
|----------------|--------------|-------------|---------|--------|------------------|
|                | Hz           | Voltage (V) | Min (V) | Max(V) | kW               |
| IQ-H18HD-1/T-I | 50           | 220-240     | 198     | 254    | 0.098            |
| IQ-H24HD-1/T-I | 50           | 220-240     | 198     | 254    | 0.190            |
| IQ-H36HD-1/T-I | 50           | 220-240     | 198     | 254    | 0.268            |
| IQ-H36HD-3/T-I | 50           | 220-240     | 198     | 254    | 0.268            |
| IQ-H48HD-3/T-I | 50           | 220-240     | 198     | 254    | 0.326            |
| IQ-H60HD-3/T-I | 50           | 220-240     | 198     | 254    | 0.326            |

## 7. Sound levels

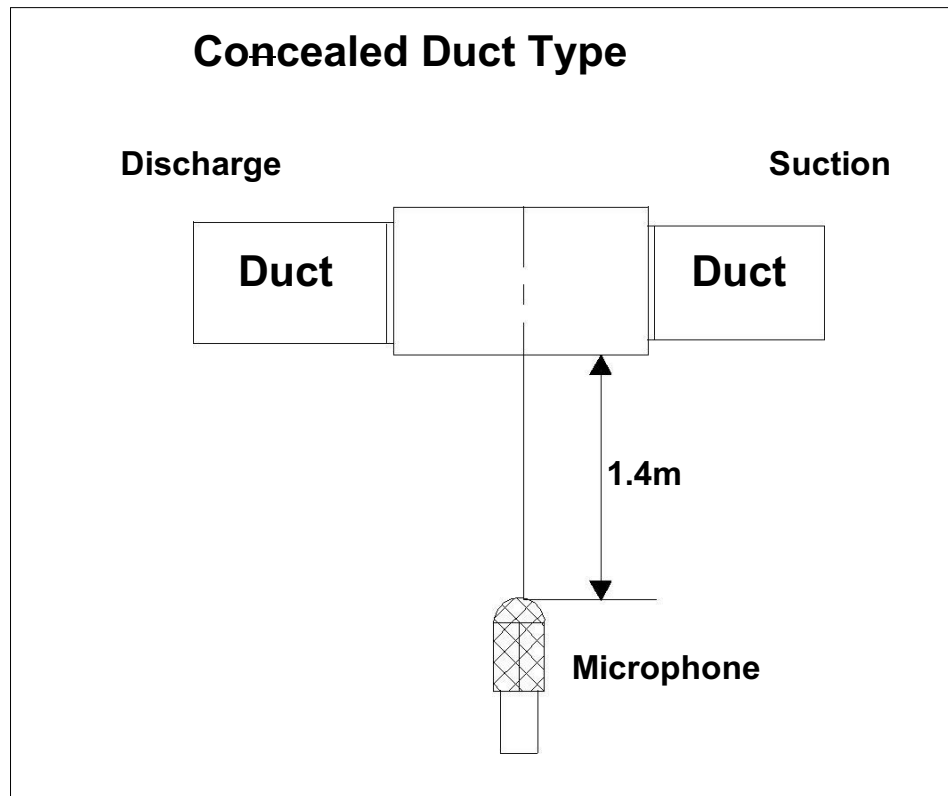

| Model          | Noise level |    |    |
|----------------|-------------|----|----|
|                | H           | M  | L  |
| IQ-H18HD-1/T-I | 43          | 35 | 33 |
| IQ-H24HD-1/T-I | 46          | 43 | 41 |
| IQ-H36HD-1/T-I | 46          | 44 | 42 |
| IQ-H36HD-3/T-I | 46          | 44 | 42 |
| IQ-H48HD-3/T-I | 47          | 44 | 42 |
| IQ-H60HD-3/T-I | 47          | 45 | 43 |

## 8. The Specification of Wiring

| Model                |                               |                 | IQ-H18HD-1/T-I   | IQ-H24HD-1/T-I                                   | IQ-H36HD-1/T-I |
|----------------------|-------------------------------|-----------------|------------------|--|----------------|
| Indoor power supply  |                               | V/Ph/Hz         | 220~240/1/50     |  |                |
| Outdoor power supply |                               | V/Ph/Hz         | 220~240/1/50     |  |                |
| Connection wiring    | Outdoor Power Supply          |                 | From indoor unit | Power supply individually for indoor and outdoor |                |
|                      | Power wiring for indoor unit  | mm <sup>2</sup> | 3×2.5            | 3×2.5  | 3×2.5          |
|                      | Power wiring for outdoor unit | mm <sup>2</sup> | /                | 3×2.5  | 3×2.5          |
|                      | Strong Electric Signal        | mm <sup>2</sup> | 5×2.5            | 3×0.75   | 4×0.75         |
|                      | Weak Electric Signal          | mm <sup>2</sup> | 2×0.75           | 2×0.75   | 2×0.75         |

| Model                |                               |                 | IQ-H36HD-3/T-I                                   | IQ-H48HD-3/T-I | IQ-H60HD-3/T-I |
|----------------------|-------------------------------|-----------------|--|----------------|----------------|
| Indoor power supply  |                               | V/Ph/Hz         | 220~240/1/50                                     |                |                |
| Outdoor power supply |                               | V/Ph/Hz         | 380~420/3/50                                     |                |                |
| Connection wiring    | Outdoor Power Supply          |                 | Power supply individually for indoor and outdoor |                |                |
|                      | Power wiring for indoor unit  | mm <sup>2</sup> | 3×2.5  | 3×2.5          | 3×2.5          |
|                      | Power wiring for outdoor unit | mm <sup>2</sup> | 5×2.5  | 5×2.5          | 5×2.5          |
|                      | Strong Electric Signal        | mm <sup>2</sup> | 4×0.75   | 4×0.75         | 4×0.75         |
|                      | Weak Electric Signal          | mm <sup>2</sup> | 2×0.75   | 2×0.75         | 2×0.75         |

# Ceiling & Floor Type

## 1. Features

- (1) **New design, more modern and elegant appearance.**



- (2) **Convenient installation**

--The ceiling type can be easily installed into a corner of the ceiling even if the ceiling is very narrow  
--It is especially useful when installation of an air conditioner in the center of the ceiling is impossible due to a structure such as one lighting.

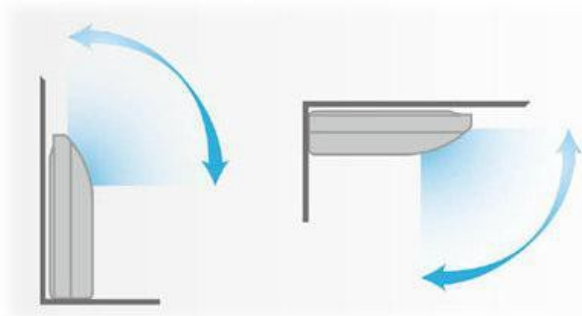

- (3) **Two direction auto swing (vertical & horizontal) and wide angle air flow**

--Air flow directional control minimizes the air resistance and produces wider air flow to vertical direction.

--The range of horizontal air discharge is widened which secures wider air flow distribution to provide more comfortable air circulation no matter where the unit is set up.



- (4) **Condensing water can be drained either from left or from right.**



**(5) Remote control and optional wired control method.**



## 2. Specifications

| Model name                 | Ceiling Floor Indoor         |                   | IQ-H18UC-1/T-I           | IQ-H24UC-1/T-I           | IQ-H36UC-1/T-I           |
|----------------------------|------------------------------|-------------------|--------------------------|--------------------------|--------------------------|
| Power supply               |                              | V//Hz/Ph          | 220-240V~/50Hz/1P        | 220-240V~/50Hz/1P        | 220-240V~/50Hz/1P        |
| Cooling                    | Capacity                     | Btu/h             | 18000                    | 24000                    | 36000                    |
|                            | Capacity                     | W                 | 5200                     | 7000                     | 10500                    |
|                            | Input                        | W                 | 1712                     | 2050                     | 3850                     |
|                            | Rated current                | A                 | 7.78                     | 8.70                     | 17.00                    |
|                            | EER                          | W/W               | 3.04                     | 3.41                     | 2.73                     |
| Heating                    | Capacity                     | Btu/h             | 18000                    | 24000                    | 40000                    |
|                            | Capacity                     | W                 | 5200                     | 7000                     | 12000                    |
|                            | Input                        | W                 | 1782                     | 1850                     | 3650                     |
|                            | Rated current                | A                 | 8.50                     | 8.0                      | 16.50                    |
|                            | COP                          | W/W               | 3.29                     | 3.78                     | 3.29                     |
| Indoor coil                | Number of row                |                   | 2                        | 2                        | 2                        |
|                            | Fin spacing                  | mm                | 1.5                      | 1.5                      | 1.5                      |
|                            | Fin material                 |                   | Hydrophilic & Louver Fin | Hydrophilic & Louver Fin | Hydrophilic & Louver Fin |
|                            | Tube outside diameter        | mm                | φ7                       | φ7                       | φ7                       |
|                            | Tube material                |                   | Innergroover tube type   | Innergroover tube type   | Innergroover tube type   |
|                            | Coil length x height x width | mm                | 795x294x25.4             | 795×294×25.4             | 940×294×25.4             |
|                            | Number of circuit            |                   | 5                        | 6                        | 6                        |
| Indoor fan motor           | Brand                        |                   | Broad-ocean              | Broad-ocean              | Broad-ocean              |
|                            | Model                        |                   | YSK36-4P                 | Y6S443B5136              | YSK125-4C-1              |
|                            | Input                        | W                 | 86/82/74/64              | 136/122/112/90           | 166/156/144/128          |
|                            | Running current              | A                 | 0.41/0.38/0.35/0.31      | 0.64/0.58/0.53/0.43      | 0.75/0.71/0.69/0.59      |
|                            | Capacitor                    | uF                | 2.5                      | 2.5                      | 4.5                      |
|                            | Applied QTY.                 |                   | 1                        | 1                        | 1                        |
|                            | Speed (Hi/Me/Lo)             | rpm               | 985/940/850/740          | 1230/1150/1045/860       | 1250/1170/1085/935       |
| Indoor air flow (Hi/Me/Lo) |                              | m <sup>3</sup> /h | 900/800/700              | 1200/1050/900            | 1700/1300/1100           |

|                               |                 |       |                   |                   |                   |
|-------------------------------|-----------------|-------|-------------------|-------------------|-------------------|
| Indoor noise level (Hi/Me/Lo) |                 | dB(A) | 43/41/38          | 45/43/40          | 45/43/40          |
| Indoor dimension              | Unit (WxHxD)    | mm    | 1055×675×235      | 1055×675×235      | 1275×675×235      |
|                               | Packing (WxHxD) | mm    | 1130x748x305      | 1130x748x305      | 1350x748x305      |
| Indoor weight                 | Net             | kg    | 23                | 23                | 29                |
|                               | Gross           | kg    | 29                | 29                | 35                |
| Refrigerant                   | Type            |       | R410A             | R410A             | R410A             |
| Refrigerant pipe              | Liquid side     | mm    | φ6.35             | 9.52              | 9.52              |
|                               | Gas side        | mm    | φ12.7             | φ15.88            | φ15.88            |
| Drainage water pipe diameter  |                 | mm    | OD25              | OD25              | OD25              |
| Ambient temperature range     | Cooling         | ℃     | 21 ~ 43           | 21 ~ 43           | 21 ~ 43           |
|                               | Heating         | ℃     | -7 ~ 24           | -7 ~ 24           | -7 ~ 24           |
| Operation Control             |                 |       | Remote controller | Remote controller | Remote controller |

| Model name   | Ceiling Floor Indoor |          | IQ-H36UC-3/T-I           | IQ-H48UC-3/T-I           | IQ-H60UC-3/T-I           |
|--------------|----------------------|----------|--------------------------|--------------------------|--------------------------|
| Power supply |                      | V//Hz/Ph | 220-240V~/50Hz/1P        | 220-240V~/50Hz/1P        | 220-240V~/50Hz/1P        |
| Cooling      | Capacity             | Btu/h    | 36000                    | 48000                    | 55000                    |
|              | Capacity             | W        | 10550                    | 14000                    | 16119                    |
|              | Input                | W        | 3578                     | 4551                     | 5594                     |
|              | Rated current        | A        | 7.8                      | 9.30                     | 12.00                    |
|              | EER                  | W/W      | 2.95                     | 3.08                     | 2.88                     |
| Heating      | Capacity             | Btu/h    | 40000                    | 50000                    | 60500                    |
|              | Capacity             | W        | 12000                    | 14650                    | 17731                    |
|              | Input                | W        | 3468                     | 4058                     | 5147                     |
|              | Rated current        | A        | 7.2                      | 9.50                     | 12.40                    |
|              | COP                  | W/W      | 3.46                     | 3.61                     | 3.44                     |
| Indoor coil  | Number of row        |          | 2                        | 3                        | 2                        |
|              | Fin spacing          | mm       | 1.5                      | 1.5                      | 1.5                      |
|              | Fin material         |          | Hydrophilic & Louver Fin | Hydrophilic & Louver Fin | Hydrophilic & Louver Fin |

|                               |                              |                   |                        |                        |                        |
|-------------------------------|------------------------------|-------------------|------------------------|------------------------|------------------------|
|                               | Tube outside diameter        | mm                | φ7                     | φ7                     | φ7                     |
|                               | Tube material                |                   | Innergroover tube type | Innergroover tube type | Innergroover tube type |
|                               | Coil length x height x width | mm                | 940×294×25.4           | 1300×294×38.1          | 1300×294×25.4          |
|                               | Number of circuit            |                   | 6                      | 10                     | 6                      |
| Indoor fan motor              | Brand                        |                   | Broad-ocean            | Broad-ocean            | Broad-ocean            |
|                               | Model                        |                   | YSK125-4C-1            | Y6S443B5137            | Y6S443B8108            |
|                               | Input                        | W                 | 166/156/144/128        | 112/104/98/92          | 180/164/112/92         |
|                               | Running current              | A                 | 0.75/0.71/0.69/0.59    | 0.51/0.48/0.45/0.44    | 0.81/0.78/0.55/0.44    |
|                               | Capacitor                    | uF                | 4.5                    | 3.5                    | 6.0                    |
|                               | Applied QTY.                 |                   | 1                      | 2                      | 2                      |
|                               | Speed (Hi/Me/Lo)             | rpm               | 1250/1170/1085/935     | 1220/1160/1010/930     | 1250/1160/1000/760     |
| Indoor air flow (Hi/Me/Lo)    |                              | m <sup>3</sup> /h | 1700/1300/1100         | 2177/1689/1434         | 2177/1689/1434         |
| Indoor noise level (Hi/Me/Lo) |                              | dB(A)             | 45/43/40               | 52/49/46               | 52/49/46               |
| Indoor dimension              | Unit (WxHxD)                 | mm                | 1275×675×235           | 1635x675x235           | 1635x675x235           |
|                               | Packing (WxHxD)              | mm                | 1350x748x305           | 1710x748x305           | 1710x748x305           |
| Indoor weight                 | Net                          | kg                | 29                     | 40                     | 38                     |
|                               | Gross                        | kg                | 35                     | 46                     | 44                     |
| Refrigerant                   | Type                         |                   | R410A                  | R410A                  | R410A                  |
| Refrigerant pipe              | Liquid side                  | mm                | 9.52                   | 9.52                   | 9.52                   |
|                               | Gas side                     | mm                | φ15.88                 | φ19.05                 | φ19.05                 |
| Drainage water pipe diameter  |                              | mm                | OD25                   | OD25                   | OD25                   |
| Ambient temperature range     | Cooling                      |                   |                        | °C                     | 21 ~ 43                |
|                               | Heating                      | °C                | -7 ~ 24                | -7 ~ 24                | -7 ~ 24                |
| Operation Control             |                              |                   | Remote controller      | Remote controller      | Remote controller      |

Notes:

- Nominal cooling capacities are based on the following conditions: indoor temp: 27°CDB, 19°CWB; Outdoor temp: 35°CDB; Equivalent ref. piping: 7.5m (horizontal)
- Nominal heating capacities are based on the following conditions: Indoor temp: 20°CDB; Outdoor temp: 7°CDB, 6°CWB; Equivalent ref. piping: 7.5m (horizontal)
- Actual noise level may differ, depending on the room structure, etc, since these noise values are from an

anechoic room.

Remark: The above design and specification are subject to change without prior notice for product improvement.

### 3. Dimensions

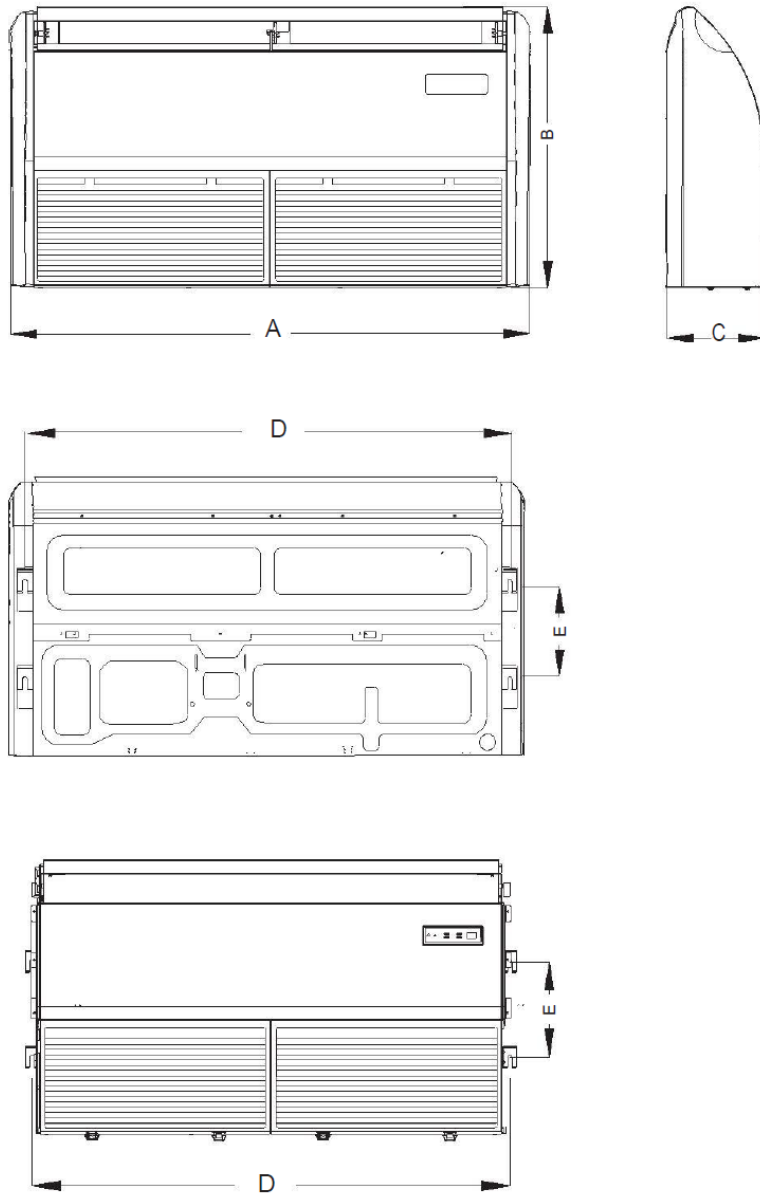

| Capacity / Dimension | 18000/24000Btu/h | 36000Btu/h | 48000/60000Btu/h |
|----------------------|------------------|------------|------------------|
| A                    | 1055             | 1275       | 1635             |
| B                    | 675              | 675        | 675              |
| C                    | 235              | 235        | 235              |
| D                    | 980              | 1200       | 1560             |
| E                    | 240              | 240        | 240              |

### 4. Service Space

## ● Floor console

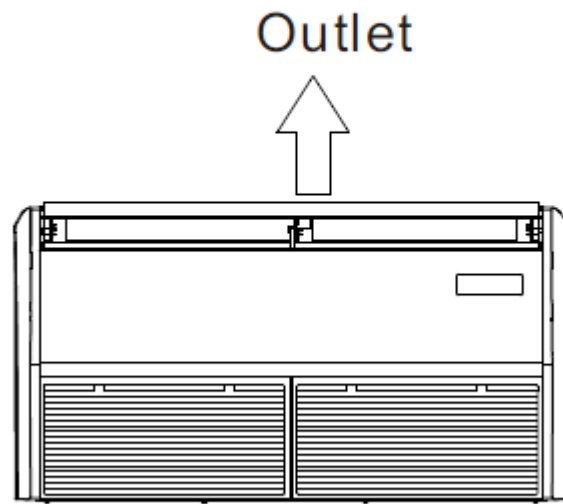

## ● Under ceiling

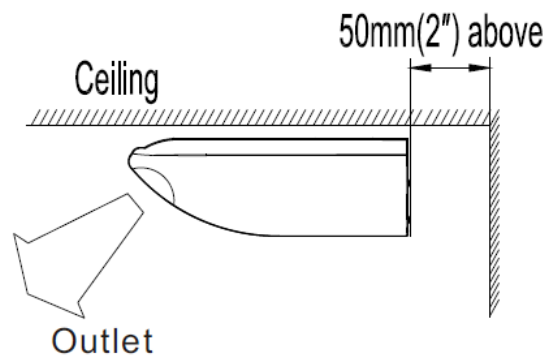
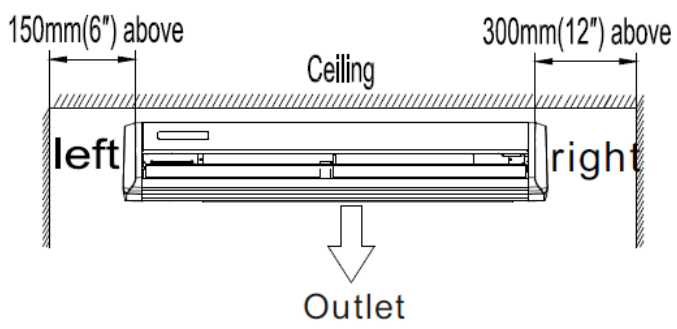

# 5. Wiring Diagrams

## 5.1 IQ-H12UC-1/T-I; IQ-H18UC-1/T-I

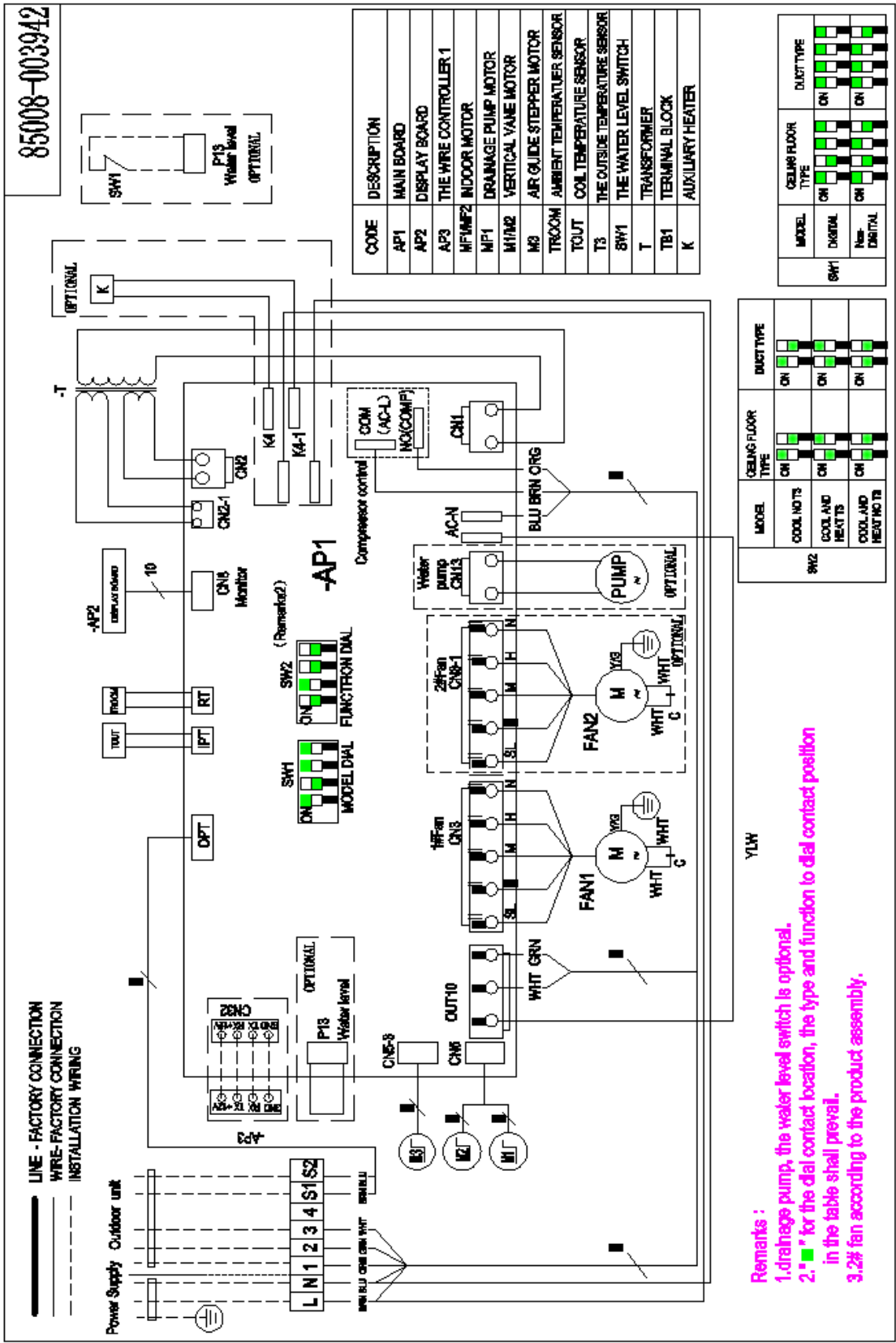

## 5.2 IQ-H24UC-1/T-I

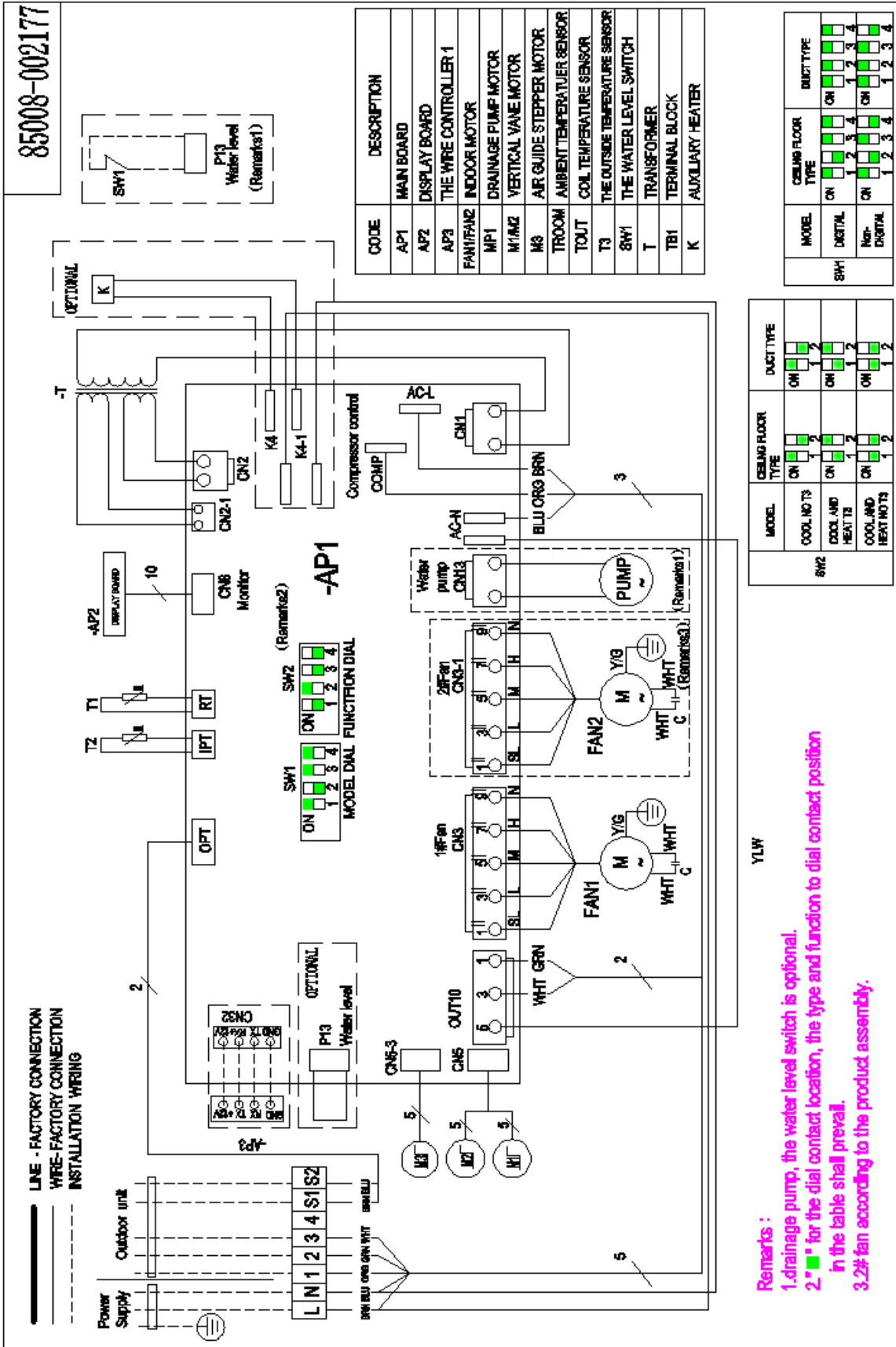

### 5.3 IQ-H36HD-3/T-I & IQ-H48HD-3/T-I & IQ-H60HD-3/T-I

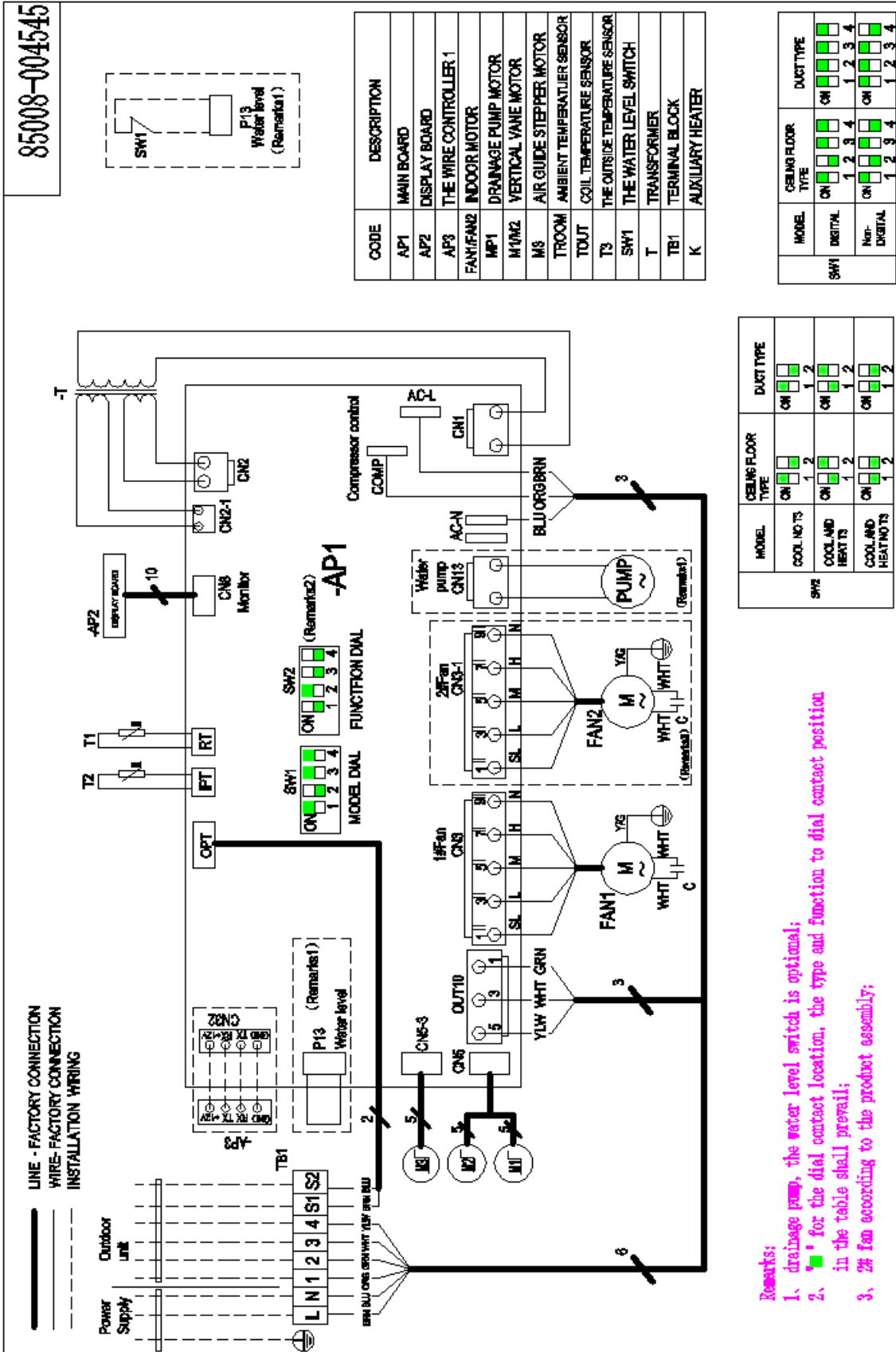

## 6. Air Velocity and Temperature Distributions

Discharge angle 60° (CEILING)

Airflow velocity

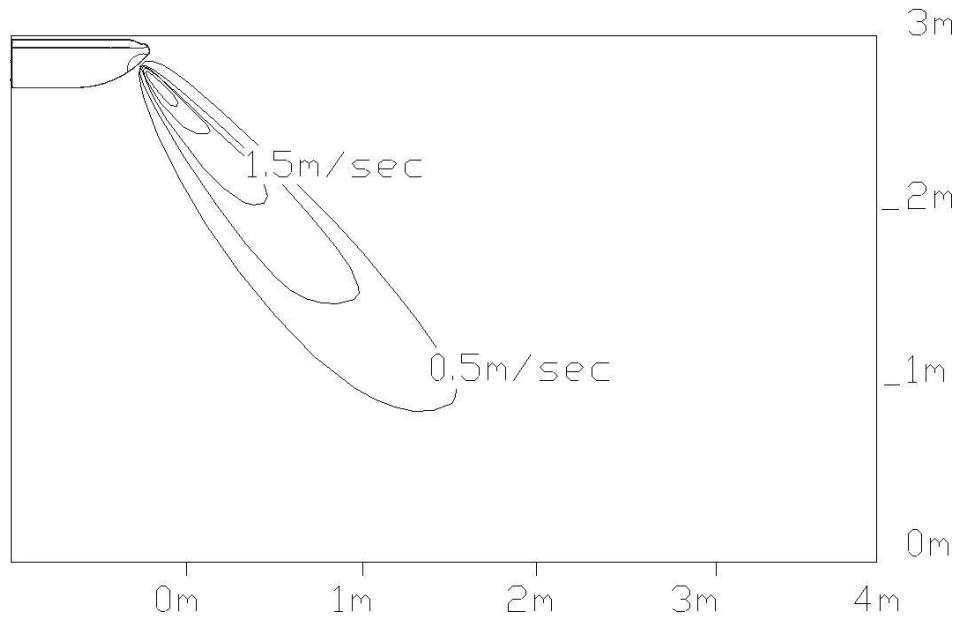

Temperature

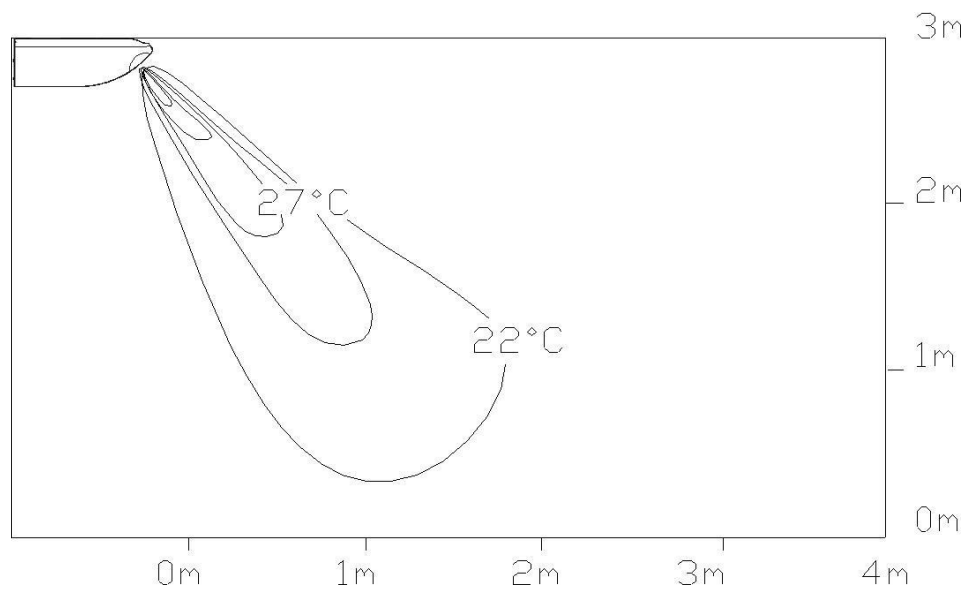

**Discharge angle 60°(FLOOR)**

Temperature

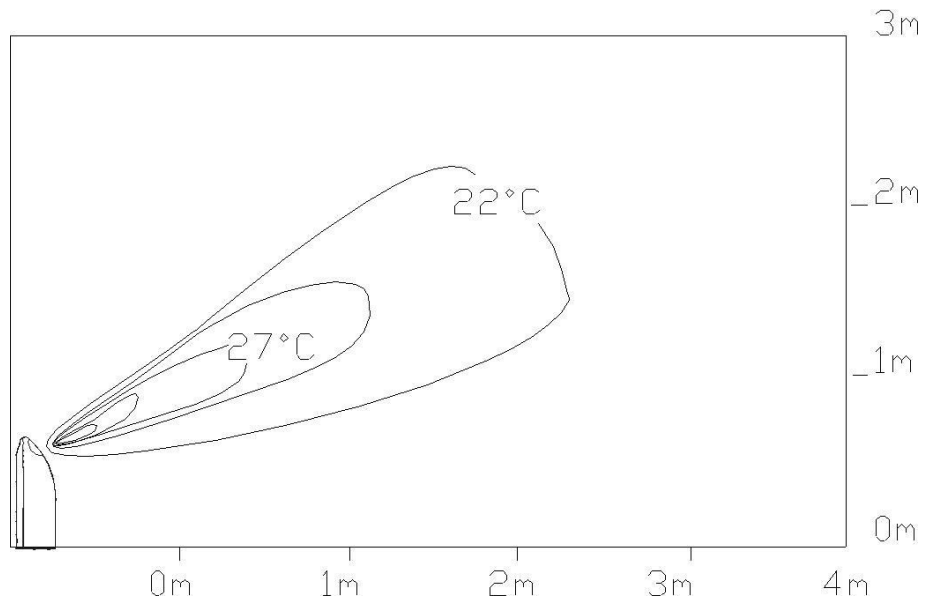

Airflow velocity

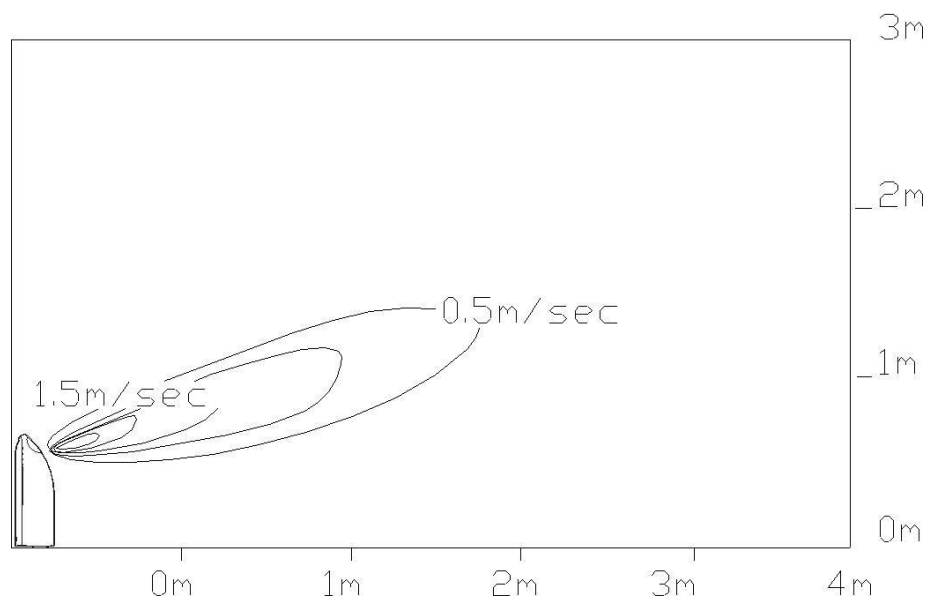

## 7. Electric Characteristics

| Model                            | Indoor Units |          |      |      | Indoor Fan |
|----------------------------------|--------------|----------|------|------|------------|
|                                  | Hz           | Voltage  | Min. | Max. | kW         |
| IQ-H12UC-1/T-I<br>IQ-H18UC-1/T-I | 50           | 220-240V | 198V | 254V | 0.086      |
| IQ-H24UC-1/T-I                   | 50           | 220-240V | 198V | 254V | 0.136      |
| IQ-H36UC-1/T-I                   | 50           | 220-240V | 198V | 254V | 0.166      |
| IQ-H36UC-3/T-I                   | 50           | 220-240V | 198V | 254V | 0.166      |
| IQ-H48UC-3/T-I                   | 50           | 220-240V | 198V | 254V | 0.112*2    |
| IQ-H60UC-3/T-I                   | 50           | 220-240V | 198V | 254V | 0.180*2    |

## 8. Sound Levels

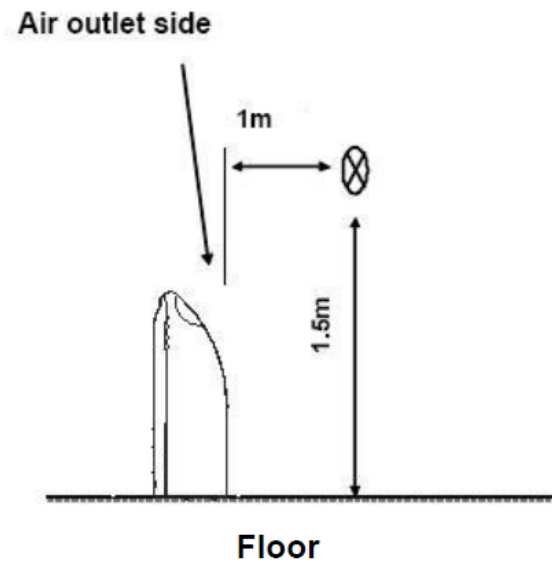
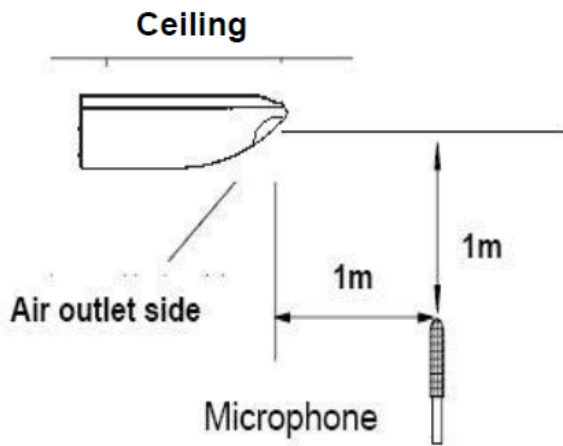

| Model          | Noise level |    |    |
|----------------|-------------|----|----|
|                | H           | M  | L  |
| IQ-H12UC-1/T-I | 43          | 41 | 38 |
| IQ-H18UC-1/T-I |             |    |    |
| IQ-H24UC-1/T-I | 45          | 43 | 40 |
| IQ-H36UC-1/T-I | 45          | 43 | 40 |
| IQ-H36UC-3/T-I | 45          | 43 | 40 |
| IQ-H48UC-3/T-I | 52          | 49 | 46 |
| IQ-H60UC-3/T-I | 52          | 49 | 46 |

## 9. The Specification of Wiring

| Model                |                              | IQ-H12UC-1/T-I<br>IQ-H18UC-1/T-I |                  |
|----------------------|------------------------------|----------------------------------|------------------|
| Indoor power supply  | V/Ph/Hz                      | 220~240/1/50                     |                  |
| Outdoor power supply | V/Ph/Hz                      | 220~240/1/50                     |                  |
| Connection wiring    | Outdoor Power Supply         |                                  | From indoor unit |
|                      | Power wiring for indoor unit | mm <sup>2</sup>                  | 3×2.5            |
|                      | Strong Electric Signal       | mm <sup>2</sup>                  | 5×2.5            |
|                      | Weak Electric Signal         | mm <sup>2</sup>                  | 2×0.75           |

| Model                |                               | IQ-H12UC-1/T-I<br>IQ-H18UC-1/T-I | IQ-H24UC-1/T-I   | IQ-H36UC-1/T-I                                   |
|----------------------|-------------------------------|----------------------------------|------------------|--|
| Indoor power supply  | V/Ph/Hz                       | 220~240/1/50                     |                  |  |
| Outdoor power supply | V/Ph/Hz                       | 220~240/1/50                     |                  |  |
| Connection wiring    | Outdoor Power Supply          |                                  | From indoor unit | Power supply individually for indoor and outdoor |
|                      | Power wiring for indoor unit  | mm <sup>2</sup>                  | 3×2.5            | 3×2.5  |
|                      | Power wiring for outdoor unit | mm <sup>2</sup>                  | /                | 3×2.5  |
|                      | Strong Electric Signal        | mm <sup>2</sup>                  | 5×2.5            | 4×0.75   |
|                      | Weak Electric Signal          | mm <sup>2</sup>                  | 2×0.75           | 2×0.75   |

| Model                |                               | IQ-H36UC-3/T-I  | IQ-H48UC-3/T-I                                   | IQ-H60UC-3/T-I |        |
|----------------------|-------------------------------|-----------------|--|----------------|--------|
| Indoor power supply  | V/Ph/Hz                       | 220~240/1/50    |  |                |        |
| Outdoor power supply | V/Ph/Hz                       | 380~415/3/50    |  |                |        |
| Connection wiring    | Outdoor Power Supply          |                 | Power supply individually for indoor and outdoor |                |        |
|                      | Power wiring for indoor unit  | mm <sup>2</sup> | 3×2.5  | 3×2.5          | 3×2.5  |
|                      | Power wiring for outdoor unit | mm <sup>2</sup> | 5×2.5  | 5×2.5          | 5×2.5  |
|                      | Strong Electric Signal        | mm <sup>2</sup> | 4×0.75   | 4×0.75         | 4×0.75 |
|                      | Weak Electric Signal          | mm <sup>2</sup> | 2×0.75   | 2×0.75         | 2×0.75 |

# Part 3 Outdoor Units

## 1. Specifications

| Model name                  | Universal Outdoor Unit |     | IQ-H12CA-1/T-O<br>IQ-H12UC-1/T-O<br>IQ-H18CA-1/T-O<br>IQ-H18HD-1/T-O<br>IQ-H18UC-1/T-O | IQ-H24CA-1/T-O<br>IQ-H24HD-1/T-O<br>IQ-H24UC-1/T-O | IQ-H36CA-1/T-O<br>IQ-H36HD-1/T-O<br>IQ-H36UC-1/T-O |
|-----------------------------|------------------------|-----|--|--|--|
| Power supply                | V//Hz/Ph               |     | 220-240V~/50Hz/1P  | 220-240V~/50Hz/1P                                  | 220-240V~/50Hz/1P                                  |
| Max. input consumption      | W                      |     | 2200   | 2800   | 5500   |
| Max. current                | A                      |     | 11.5   | 15.0   | 25.0   |
| Starting current            | A                      |     | 36.8   | 50.0   | 82   |
| Max Operating Pressure(MPa) | Discharge              | MPa | 4.2  | 4.5  | 4.2  |
|                             | Suction                | MPa | 1.5  | 1.5  | 1.5  |
| Compressor                  | Brand                  |     | HIGHLY   | HIGHLY   | HIGHLY   |
|                             | Model                  |     | ASL180MV-C7EUT   | ASH232MV-C7EU1                                     | ATH420MV-C9EU                                      |
|                             | Type                   |     | Rotary   | Rotary   | Rotary   |
|                             | Capacity               | W   | 4870   | 5615   | 10060  |
|                             | Input                  | W   | 1227   | 1855   | 3470   |
|                             | Rated current(RLA)     | A   | 5.7  | 8.7  | 16.6   |
|                             | Locked rotor Amp(LRA)  | A   | 36   | 48   | 80   |
|                             | Thermal protector      |     | internal   | internal   | internal   |
|                             | Capacitor              | uF  | 50   | 55   | 90   |
|                             | Refrigerant oil        | ml  | 390  | 485  | 840  |
| Outdoor coil                | Number of row          |     | 2  | 2  | 2  |
|                             | Fin spacing            | mm  | 1.5  | 1.4  | 1.5  |
|                             | Fin material           |     | Louver or Corrugated Fin   | Louver or Corrugated Fin                           | Louver or Corrugated Fin                           |
|                             | Tube outside diameter  | mm  | φ7   | φ7   | φ7   |

|                     |                              |                   |                        |                        |                        |
|---------------------|------------------------------|-------------------|------------------------|------------------------|------------------------|
|                     | Tube material                |                   | Innergroover tube type | Innergroover tube type | Innergroover tube type |
|                     | Coil length x height x width | mm                | 766×510×25.4           | 820×651×36.4           | 1023X756X25.4          |
|                     | Number of circuit            |                   | 2                      | 4                      | 6                      |
| Outdoor fan motor   | Brand                        |                   | Weiling/Broad-ocean    | Dayang                 | Lifeng                 |
|                     | Model                        |                   | GZSDJ-33               | Y6S688C008L            | 210900509              |
|                     | Input                        | W                 | 96                     | 136                    | 160                    |
|                     | Output                       | W                 | 45                     | 65                     | 96                     |
|                     | Running current              | A                 | 0.44                   | 0.64                   | 0.72                   |
|                     | Capacitor                    | uF                | 3.0                    | 3                      | 6                      |
|                     | Speed                        | rpm               | 850                    | 890                    | 860                    |
| Outdoor air flow    |                              | m <sup>3</sup> /h | 2400                   | 4000                   | 4900                   |
| Outdoor noise level |                              | dB(A)             | 56                     | 54                     | 58                     |
| Outdoor dimension   | Unit (WxHxD)                 | mm                | 760x550x250            | 845×700×330            | 910×805×360            |
|                     | Packing (WxHxD)              | mm                | 863×590×361            | 960×735×430            | 1030×860×475           |
| Outdoor weight      | Net                          | kg                | 34                     | 47                     | 59                     |
|                     | Gross                        | kg                | 37                     | 50                     | 63                     |
| Refrigerant         | Type                         |                   | R410A                  | R410A                  | R410A                  |
|                     | Charge                       | g                 | 1050                   | 1900                   | 1900                   |
| Throttle type       |                              |                   | Capillary              | Capillary              | Capillary              |
| Refrigerant pipe    | Liquid side                  | mm                | 6.35                   | 9.52                   | 9.52                   |
|                     | Gas side                     | mm                | 12.70                  | 15.88                  | 15.88                  |
|                     | Max. refrigerant pipe length | m                 | 25                     | 30                     | 30                     |
|                     | Max. difference in level     | m                 | 15                     | 15                     | 20                     |
|                     | Cooling                      | °C                | 21 ~ 43                | 21 ~ 43                | 21 ~ 43                |

|                           |         |    |         |         |         |
|---------------------------|---------|----|---------|---------|---------|
| Ambient temperature range | Heating | °C | -7 ~ 24 | -7 ~ 24 | -7 ~ 24 |
|---------------------------|---------|----|---------|---------|---------|

| Model name                  | Universal Outdoor Unit |          | IQ-H36CA-3/T-O<br>IQ-H36HD-3/T-O<br>IQ-H36UC-3/T-O | TCC-48HRA/U3O(04)        | TCC-60HRA/U3O(04)        |
|-----------------------------|------------------------|----------|--|--------------------------|--------------------------|
| Power supply                |                        | V//Hz/Ph | 380-415V~/50Hz/3P                                  | 380-415V~/50Hz/3P        | 380-415V~/50Hz/3P        |
| Max. input consumption      |                        | W        | 6100   | 6600                     | 9200                     |
| Max. current                |                        | A        | 11.5   | 12.8                     | 16.0                     |
| Starting current            |                        | A        | 66   | 66.0                     | 80.0                     |
| Max Operating Pressure(MPa) | Discharge              | MPa      | 4.2  | 4.2                      | 4.2                      |
|                             | Suction                | MPa      | 1.5  | 1.5                      | 1.5                      |
| Compressor                  | Brand                  |          | HIGHLY   | HIGHLY                   | HIGHLY                   |
|                             | Model                  |          | ATH420UC-C9EU1                                     | ATH490UC3C9EQC           | ATE650SC3Q9JK            |
|                             | Type                   |          | Rotary   | Rotary                   | Rotary                   |
|                             | Capacity               | W        | 9880   | 13200                    | 16350                    |
|                             | Input                  | W        | 3280   | 3370                     | 5630                     |
|                             | Rated current(RLA)     | A        | 5.9  | 6.8                      | 9.5                      |
|                             | Locked rotor Amp(LRA)  | A        | 36   | 62                       | 65                       |
|                             | Thermal protector      |          | internal   | internal                 | internal                 |
|                             | Capacitor              | uF       | /  | /                        | /                        |
|                             | Refrigerant oil        | ml       | 1200   | 1200                     | 1850                     |
| Outdoor coil                | Number of row          |          | 2  | '1.5                     | 2                        |
|                             | Fin spacing            | mm       | 1.5  | 1.6                      | 1.6                      |
|                             | Fin material           |          | Louver or Corrugated Fin                           | Louver or Corrugated Fin | Louver or Corrugated Fin |
|                             | Tube outside diameter  | mm       | φ7   | φ7                       | φ7                       |
|                             | Tube material          |          | Innergroover tube type                             | Innergroover tube type   | Innergroover tube type   |

|                     |                              |                   |               |                   |                   |
|---------------------|------------------------------|-------------------|---------------|-------------------|-------------------|
|                     | Coil length x height x width | mm                | 1023X756X25.4 | 910×1218×25.4     | 910×1218×25.4     |
|                     | Number of circuit            |                   | 6             | 6                 | 6                 |
| Outdoor fan motor   | Brand                        |                   | Lifeng        | Lifeng/Match-well | Lifeng/Match-well |
|                     | Model                        |                   | 210900509     | YDK120-88-6P-AL-1 | YDK120-88-6P-AL-1 |
|                     | Input                        | W                 | 160           | 158×2             | 158×2             |
|                     | Output                       | W                 | 96            | 80×2              | 80×2              |
|                     | Running current              | A                 | 0.72          | 0.74×2            | 0.74×2            |
|                     | Capacitor                    | uF                | 6             | 4×2               | 4×2               |
|                     | Speed                        | rpm               | 860           | 800               | 800               |
| Outdoor air flow    |                              | m <sup>3</sup> /h | 4900          | 6300              | 6300              |
| Outdoor noise level |                              | dB(A)             | 58            | 60                | 60                |
| Outdoor dimension   | Unit (WxHxD)                 | mm                | 910×805×360   | 940x1250x340      | 940x1250x340      |
|                     | Packing (WxHxD)              | mm                | 1030×860×475  | 1030x1365x430     | 1030x1365x430     |
| Outdoor weight      | Net                          | kg                | 60            | 81                | 91                |
|                     | Gross                        | kg                | 64            | 90                | 102               |
| Refrigerant         | Type                         |                   | R410A         | R410A             | R410A             |
|                     | Charge                       | g                 | 1900          | 2900              | 3000              |
| Throttle type       |                              |                   | Capillary     | Capillary         | Capillary         |
| Refrigerant pipe    | Liquid side                  | mm                | 9.52          | 9.52              | 9.52              |
|                     | Gas side                     | mm                | 15.88         | 19.05             | 19.05             |
|                     | Max. refrigerant pipe length | m                 | 30            | 50                | 50                |
|                     | Max. difference in level     | m                 | 20            | 30                | 30                |
|                     | Cooling                      | °C                | 21 ~ 43       | 21 ~ 43           | 21 ~ 43           |

|                           |         |    |         |         |         |
|---------------------------|---------|----|---------|---------|---------|
| Ambient temperature range | Heating | °C | -7 ~ 24 | -7 ~ 24 | -7 ~ 24 |
|---------------------------|---------|----|---------|---------|---------|

Notes:

1. Nominal cooling capacities are based on the following conditions: indoor temp: 27°CDB, 19°CWB; Outdoor temp: 35°CDB; Equivalent ref. piping: 7.5m (horizontal)
2. Nominal heating capacities are based on the following conditions: Indoor temp: 20°CDB; Outdoor temp: 7°CDB, 6°CWB; Equivalent ref. piping: 7.5m (horizontal)
3. Actual noise level may differ, depending on the room structure, etc, since these noise values are from an anechoic room.

Remark: The above design and specification are subject to change without prior notice for product improvement.

## 2. Service Space

Please make sure necessary space for installation and repair

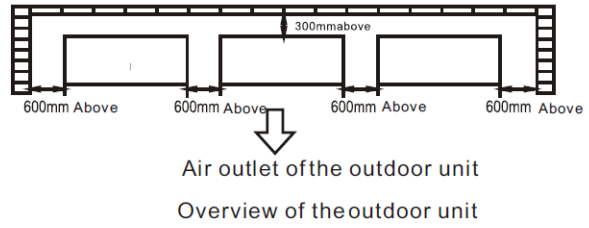
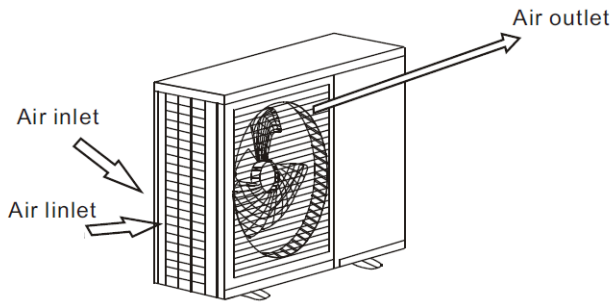

⚠ No obstruction from the air outlet of outdoor unit

At least 600mm space must be left between outdoor units as the sketch indicated.

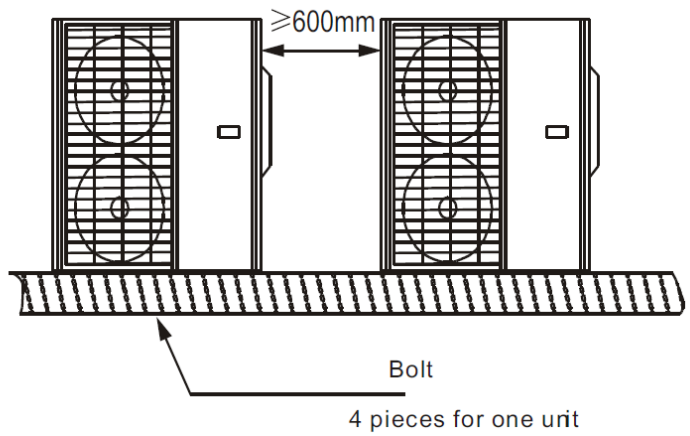
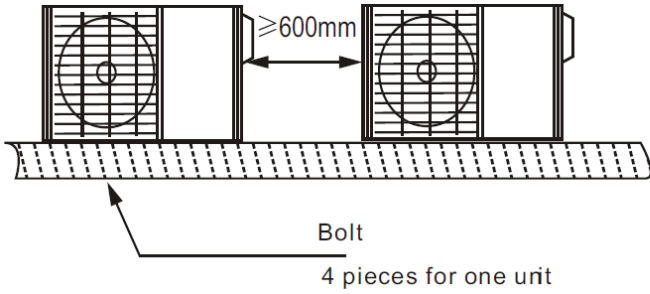

### 3. Wiring Diagrams

#### 3.1 IQ-H12CA-1/T-O;IQ-H12UC-1/T-O;IQ-H18CA-1/T-O;IQ-H18HD-1/T-O;IQ-H18UC-1/T-O

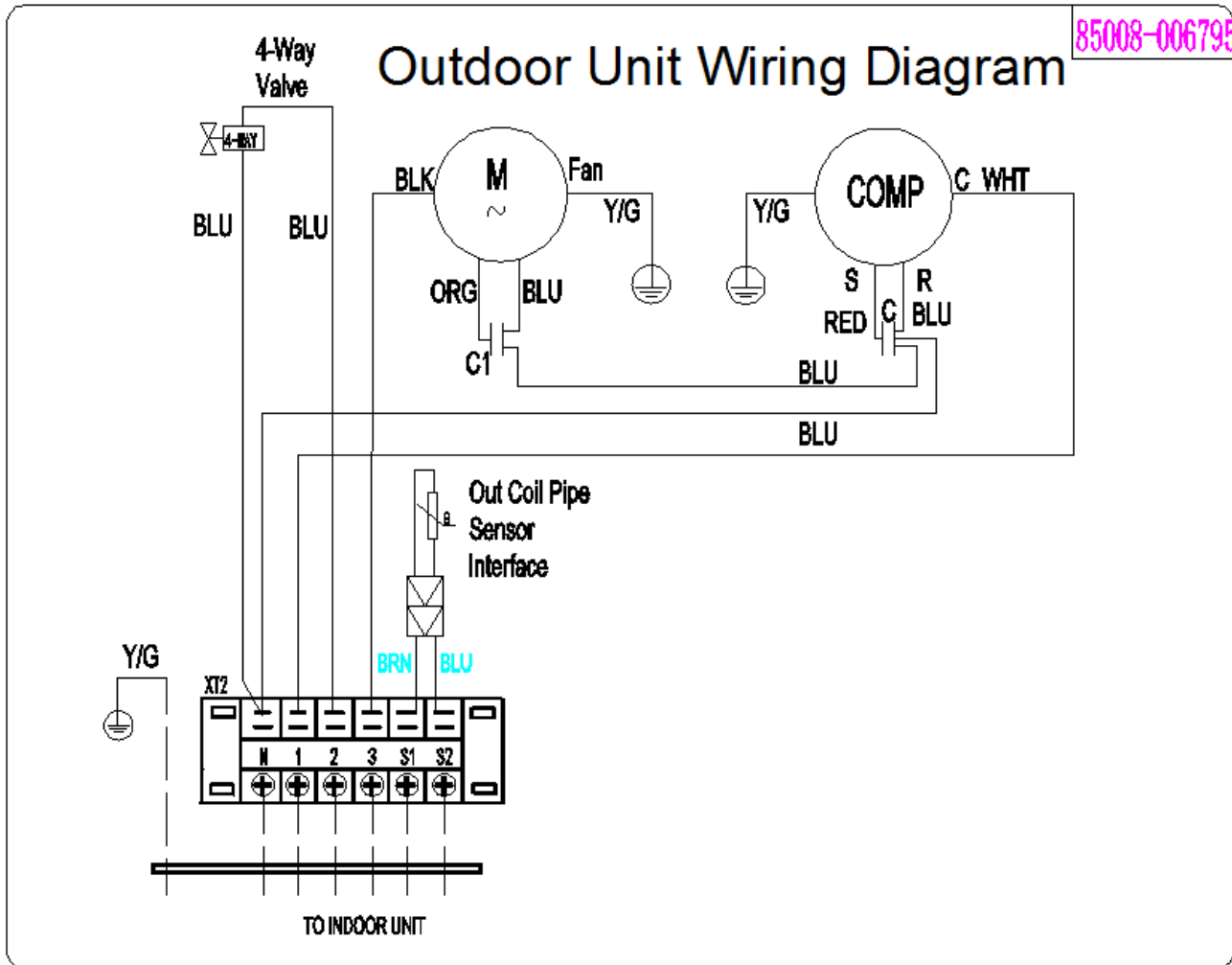

### 3.2 IQ-H24CA-1/T-O

### IQ-H24HD-1/T-O

### IQ-H24UC-1/T-O

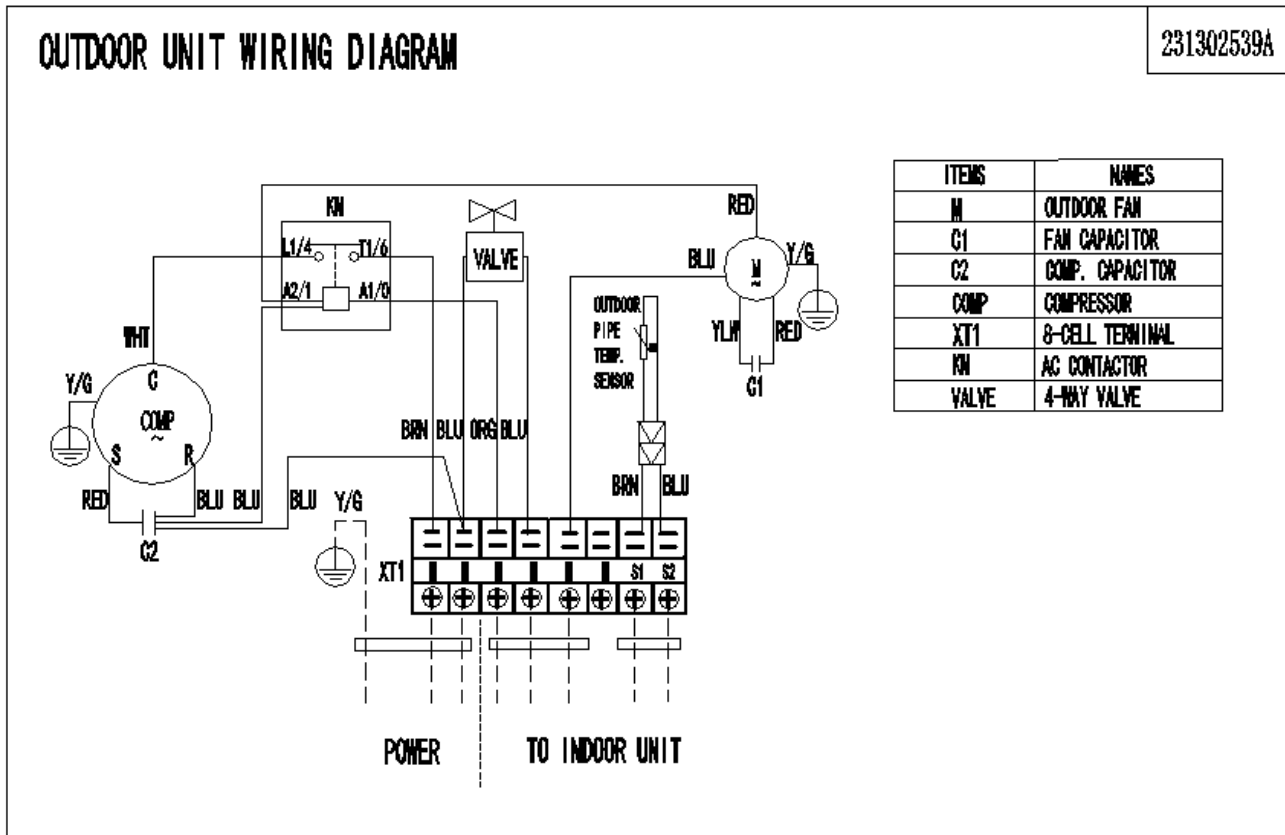

### 3.3 IQ-H36CA-1/T-O

### IQ-H36HD-1/T-O

### IQ-H36UC-1/T-O

85008-006893

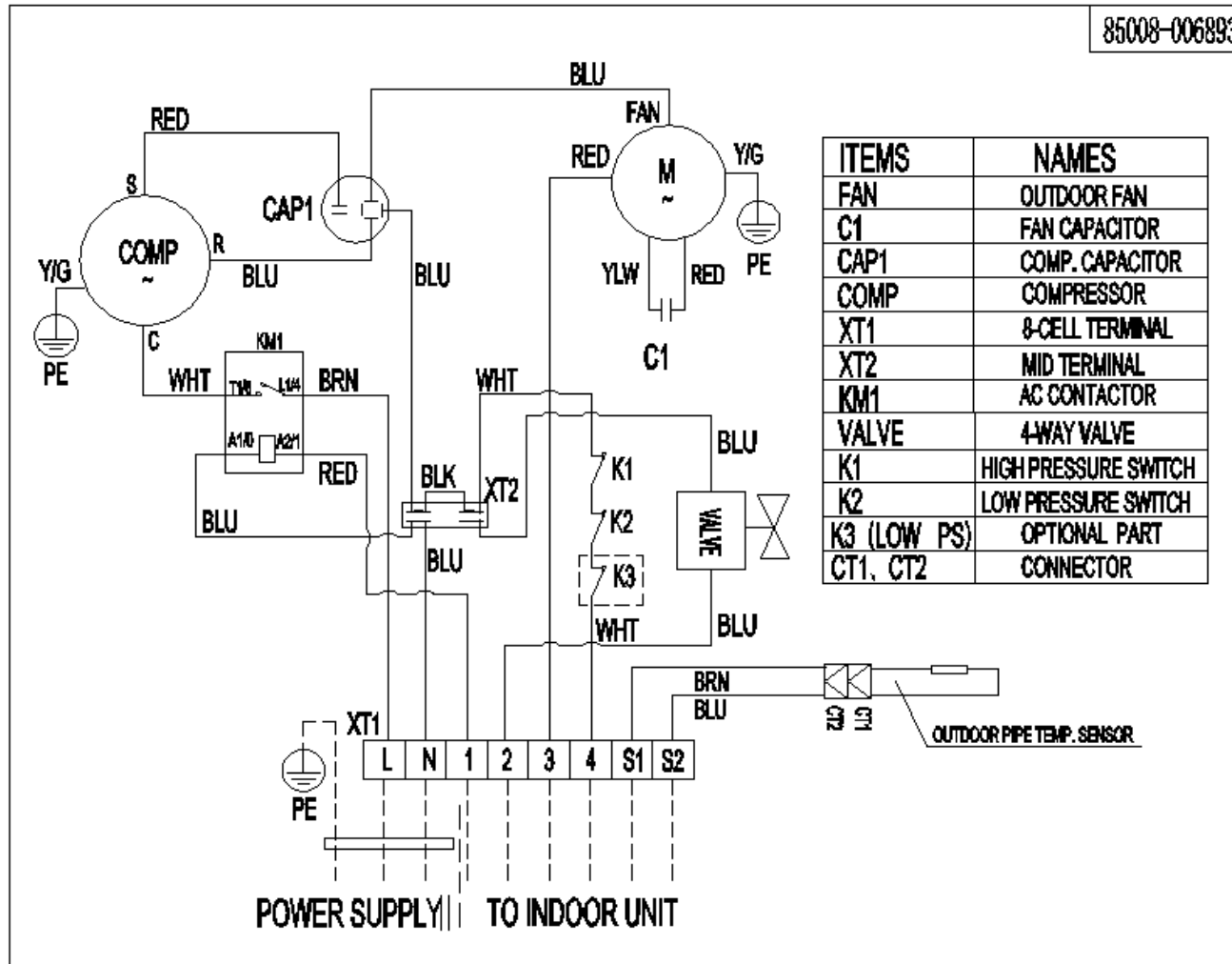

3.4 IQ-H36CA-3/T-O; IQ-H36HD-3/T-O; IQ-H36UC-3/T-O & IQ-H48CA-3/T-O; IQ-H48HD-3/T-O; IQ-H48UC-3/T-O & IQ-H60CA-3/T-O; IQ-H60HD-3/T-O; IQ-H60UC-3/T-O

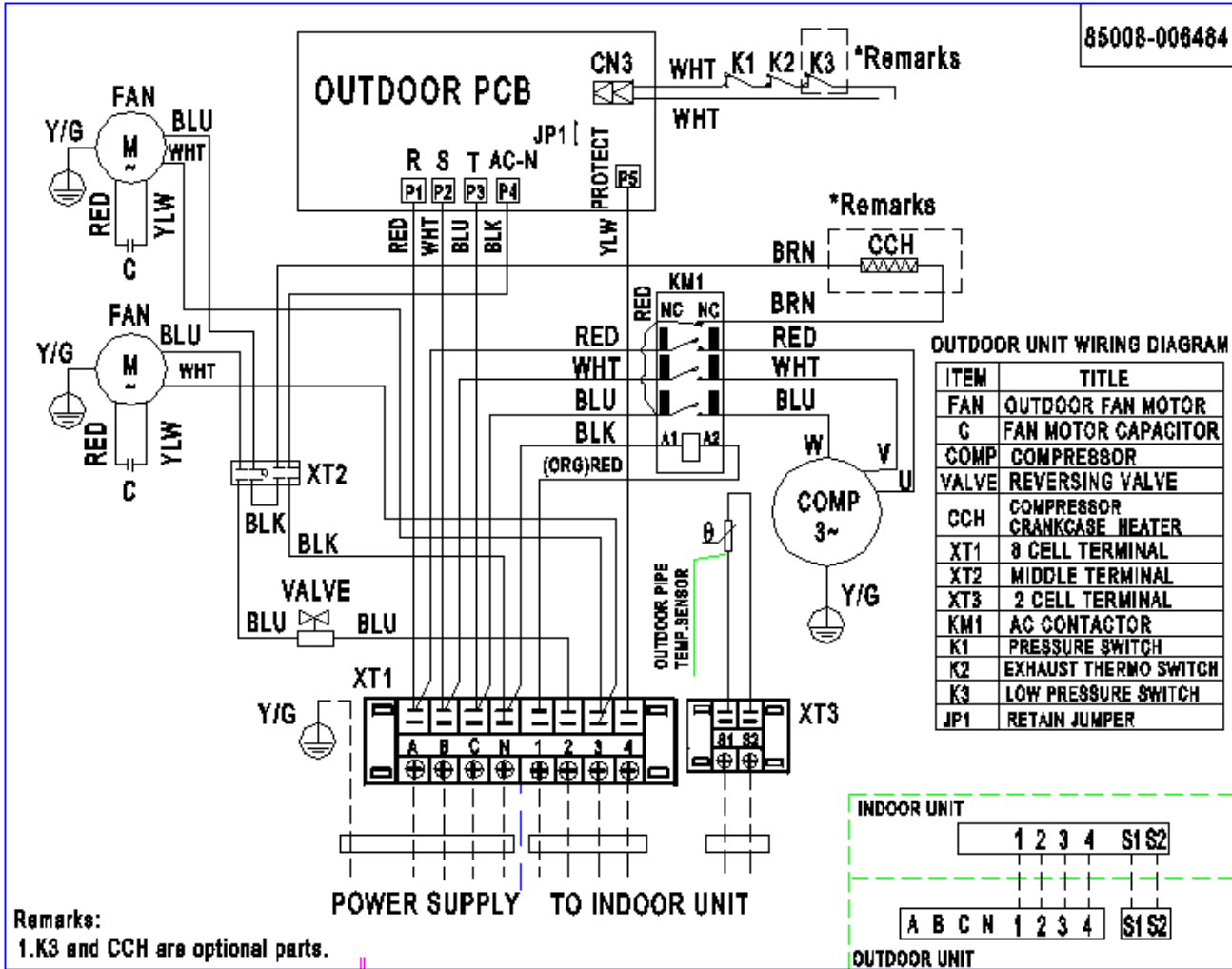

## 4. Electric Characteristics

| Model  | Hz | Outdoor Unit |         |         | Outdoor unit fan motor |
|--|----|--------------|---------|---------|------------------------|
|  |    | Voltage(V)   | Min.(V) | Max.(V) | kW                     |
| IQ-H12CA-1/T-O<br>IQ-H12UC-1/T-O<br>IQ-H18CA-1/T-O<br>IQ-H18HD-1/T-O<br>IQ-H18UC-1/T-O | 50 | 220~240      | 198     | 254     | 0.096                  |
| IQ-H24CA-1/T-O<br>IQ-H24HD-1/T-O<br>IQ-H24UC-1/T-O                                     | 50 | 220~240      | 198     | 254     | 0.136                  |
| IQ-H36CA-1/T-O<br>IQ-H36HD-1/T-O<br>IQ-H36UC-1/T-O                                     | 50 | 220~240      | 198     | 254     | 0.160                  |
| IQ-H36CA-3/T-O<br>IQ-H36HD-3/T-O<br>IQ-H36UC-3/T-O                                     | 50 | 380~415      | 342     | 450     | 0.160                  |
| IQ-H48CA-3/T-O<br>IQ-H48HD-3/T-O<br>IQ-H48UC-3/T-O                                     | 50 | 380~415      | 342     | 450     | 0.158*2                |
| IQ-H60CA-3/T-O<br>IQ-H60HD-3/T-O<br>IQ-H60UC-3/T-O                                     | 50 | 380~415      | 342     | 450     | 0.158*2                |

## 5. Operation Limits

| Operation mode    | Outdoor temperature(°C) | Room temperature(°C) |
|-------------------|-------------------------|----------------------|
| Cooling operation | 21~43                   | 17~30                |
| Heating operation | -7~24                   | 17~30                |

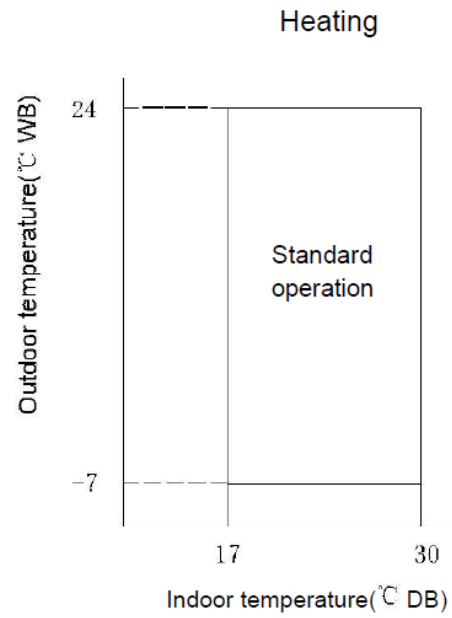
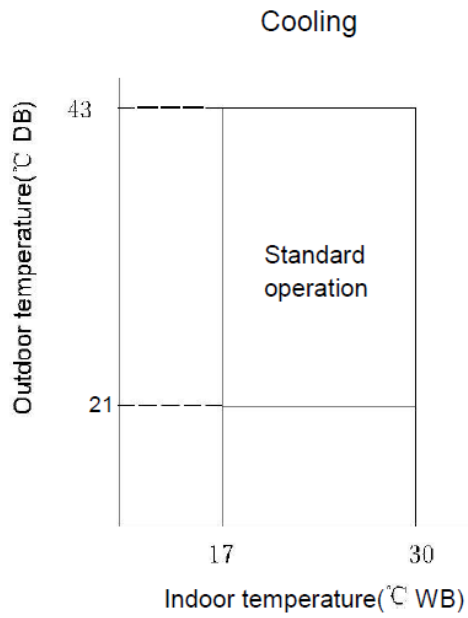

Note: Above chart is for low ambient model

## 6. Sound Levels

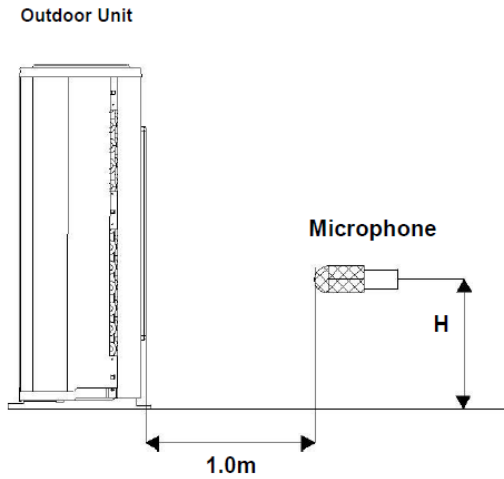

Note:  $H = 0.5 \times$  height of outdoor unit

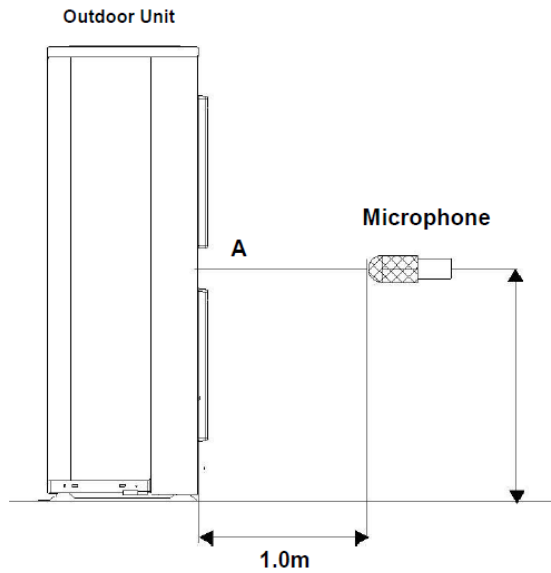

Note: The point A is in the middle of the whole outdoor panel.

| Model  | Noise level dB(A) |
|--|-------------------|
| IQ-H12CA-1/T-O;IQ-H12UC-1/T-O;IQ-H18CA-1/T-O;IQ-H18HD-1/T-O;IQ-H18UC-1/T-O | 56                |
| IQ-H24CA-1/T-O; IQ-H24HD-1/T-O;IQ-H24UC-1/T-O                              | 54                |
| IQ-H36CA-1/T-O;IQ-H36HD-1/T-O;IQ-H36UC-1/T-O                               | 58                |
| IQ-H36CA-3/T-O;IQ-H36HD-3/T-O;IQ-H36UC-3/T-O                               | 58                |
| IQ-H48CA-3/T-O; IQ-H48HD-3/T-O; IQ-H48UC-3/T-O                             | 60                |
| IQ-H60CA-3/T-O; IQ-H60HD-3/T-O; IQ-H60UC-3/T-O                             | 60                |

## 7. Troubleshooting

### 7.1 Self-diagnosis

Troubleshooting Ceiling\Duct\Ceiling & Floor

| <b>Display</b> | <b>Explanation</b>   |
|----------------|--|
| E1             | Indoor temperature sensor failure  |
| E2             | Evaporator temperature sensor failure  |
| E3             | Condenser temperature sensor failure   |
| E4             | Outdoor unit protection (High pressure protection、Low pressure protection、Compressor discharge temperature protection、Power supply faults) |
| Ed             | EEPROM malfunction of indoor main control board  |
| d3/EL          | Full-loading water alarm   |
| C5             | Bad communication between indoor PCB & wire controller (Wire controller display)   |

## 7.2 Solving steps for typical malfunction

### a. E1 —Indoor room temperature sensor failure

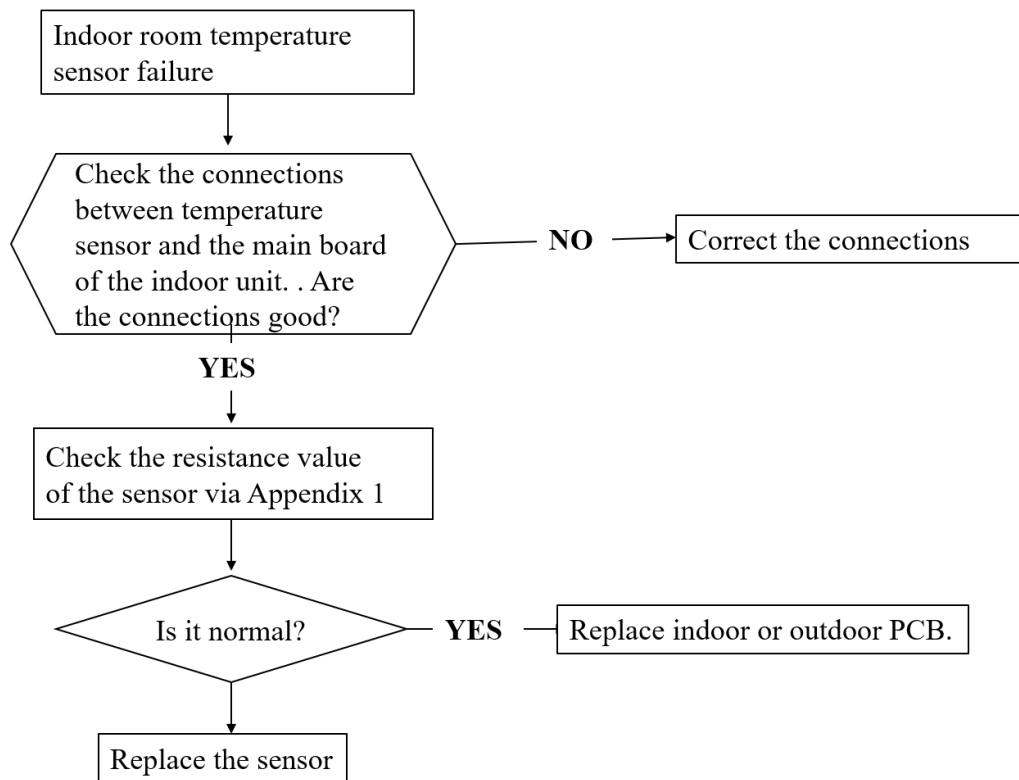

**b. E2—Evaporator sensor failure**

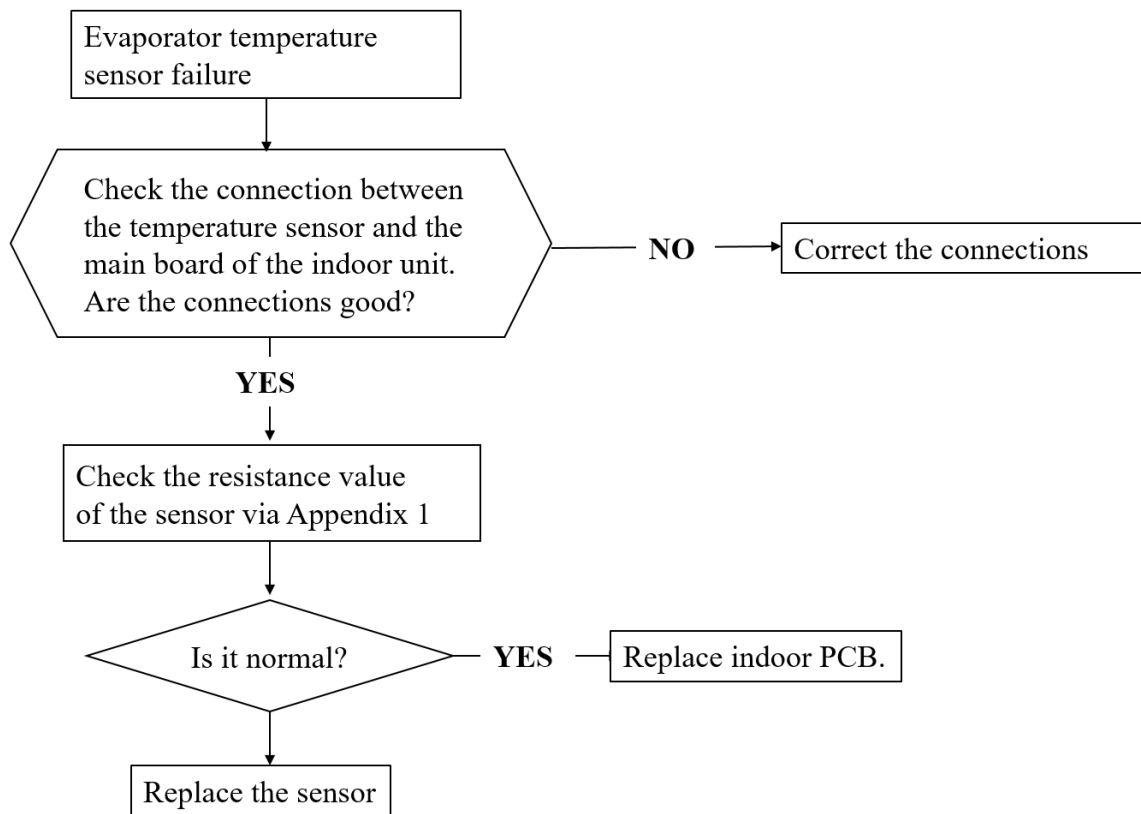

**c. E3—Condenser temperature sensor failure**

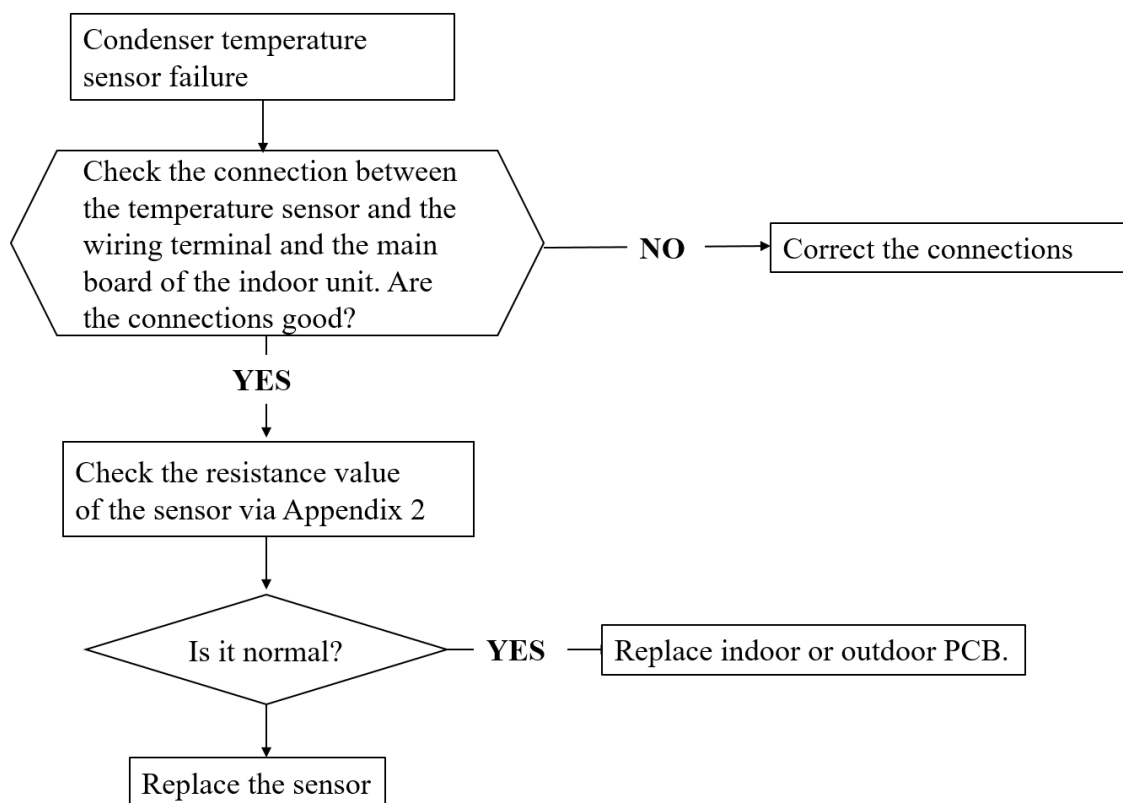

**d. E4—Outdoor unit malfunction**

- 1) Check the wiring

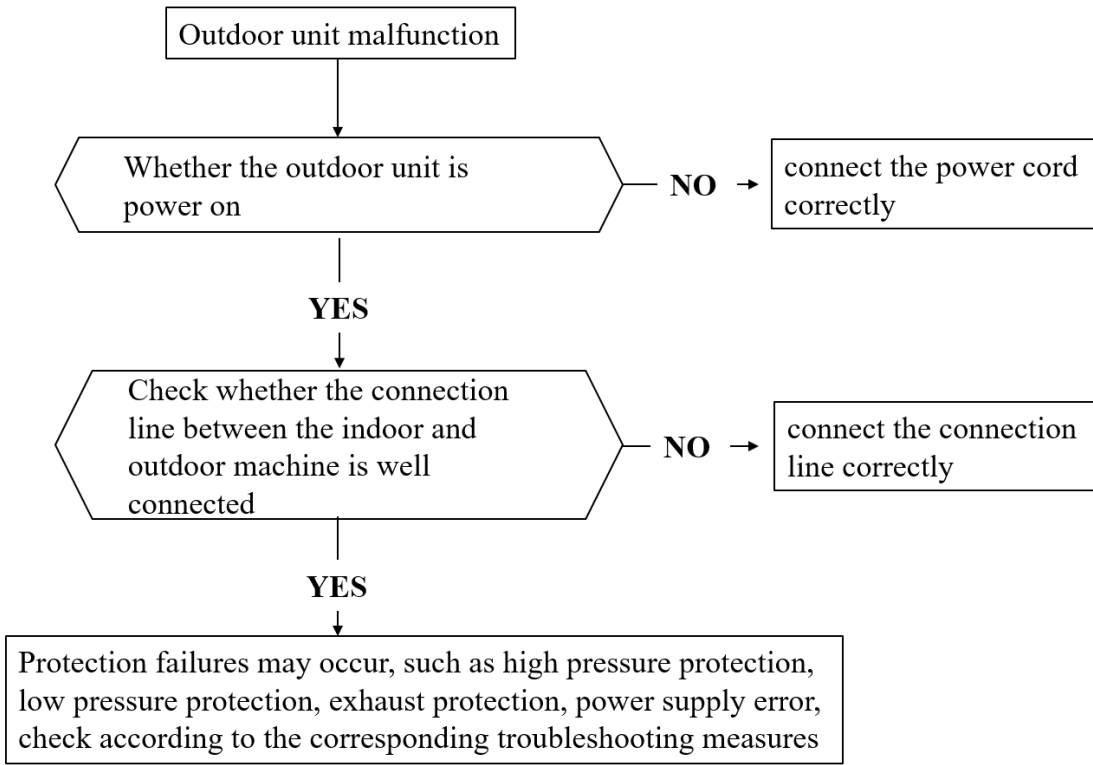

## 2) Low pressure protection

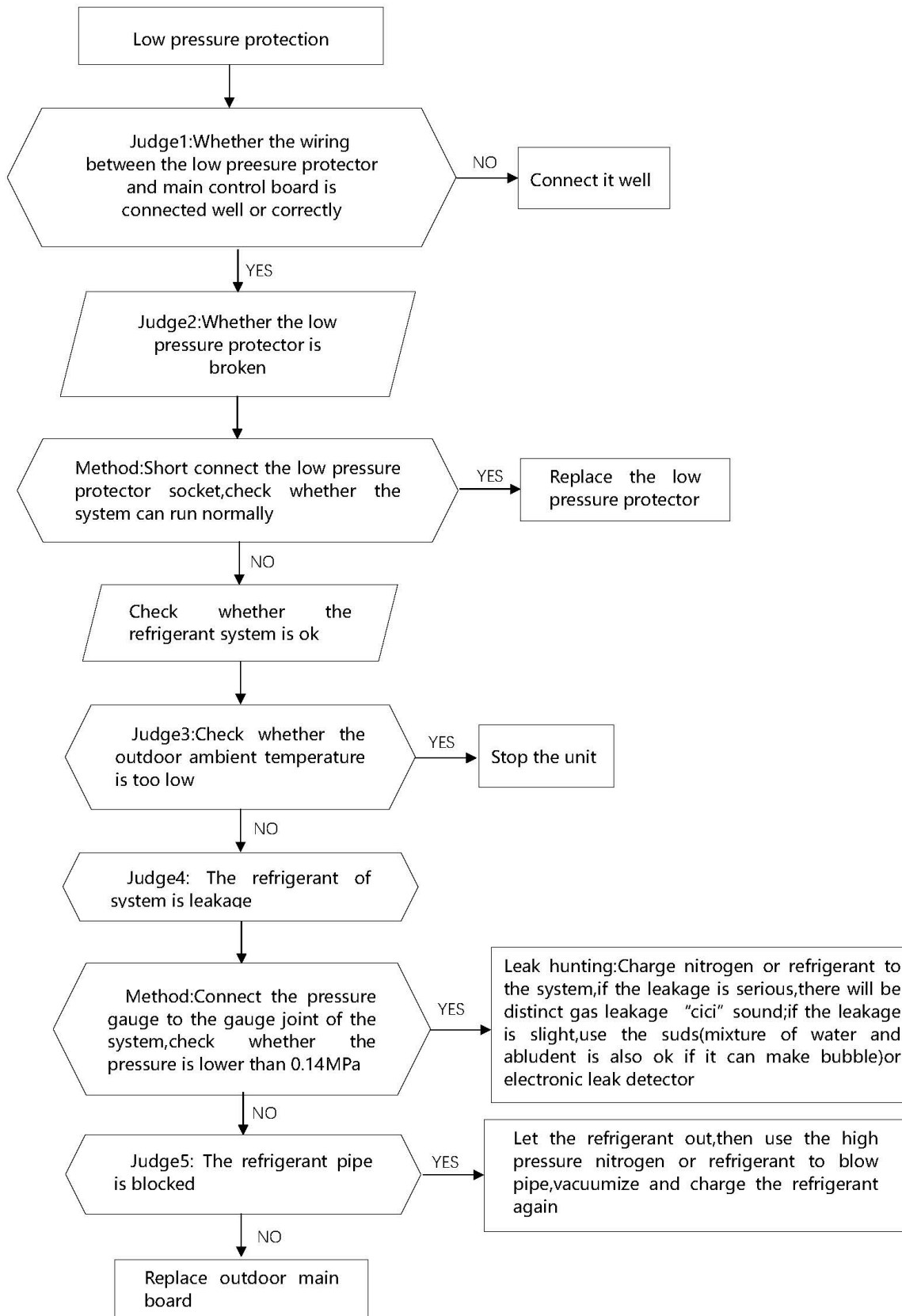

### 3) High pressure protection

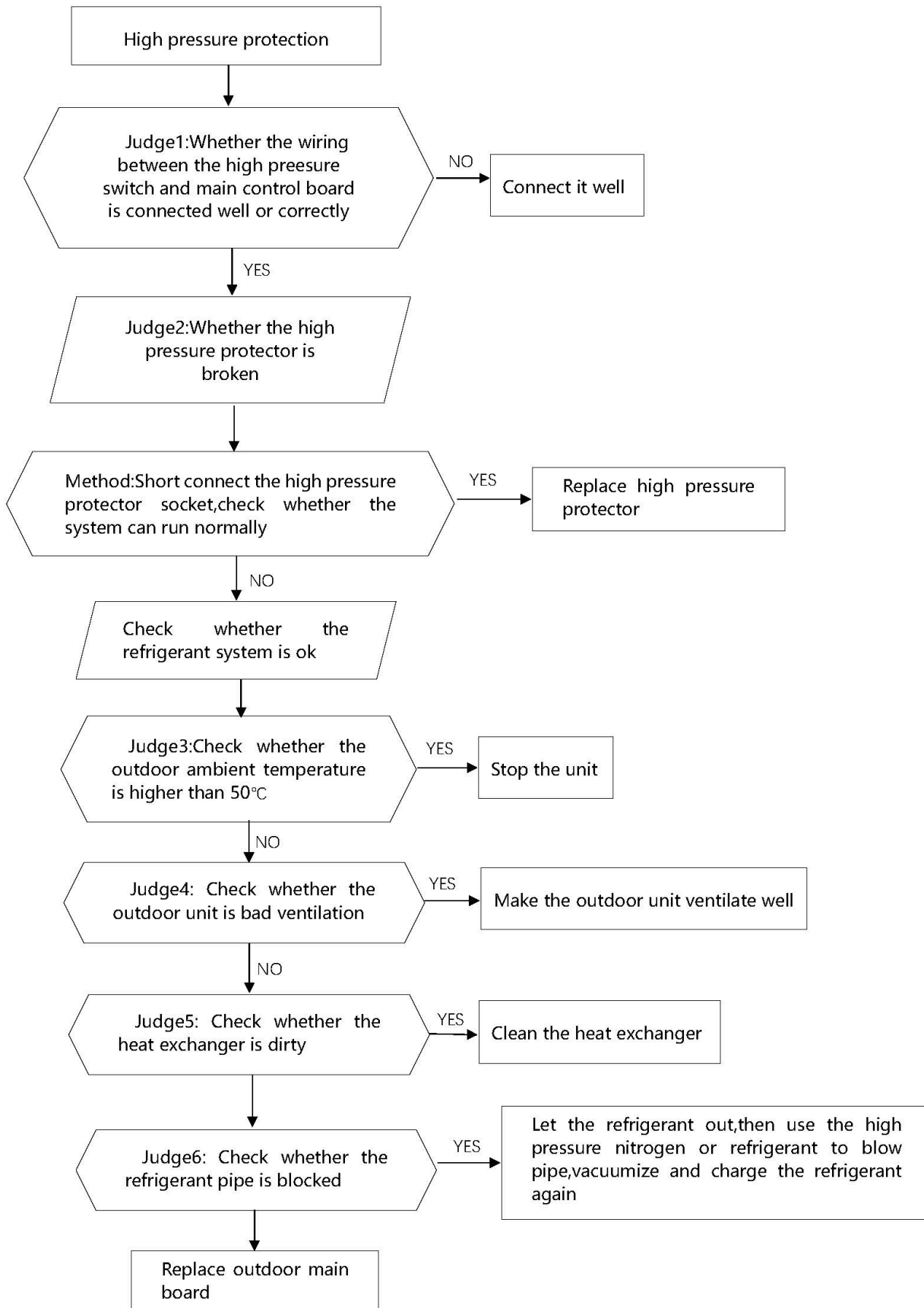

#### 4) Temperature protection of compressor discharge

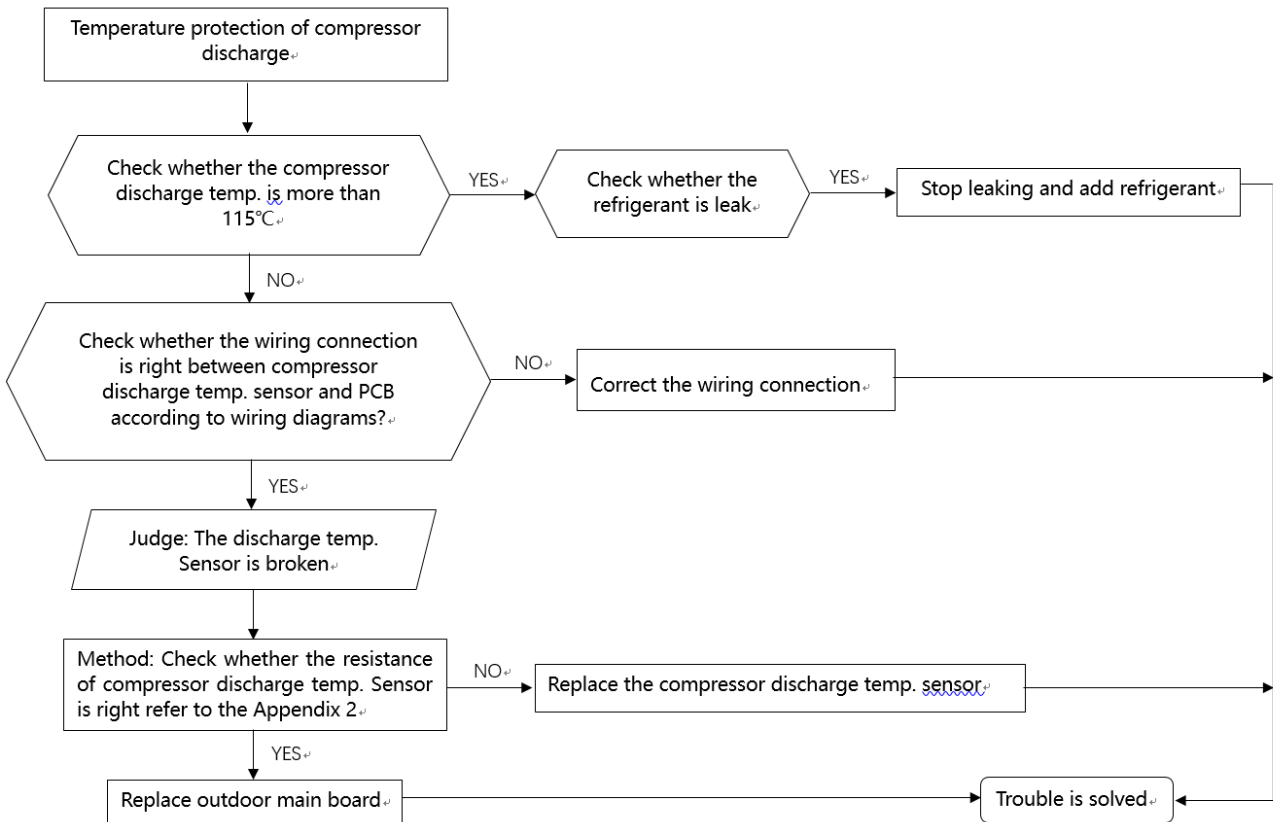

#### 5) Phase sequence error:

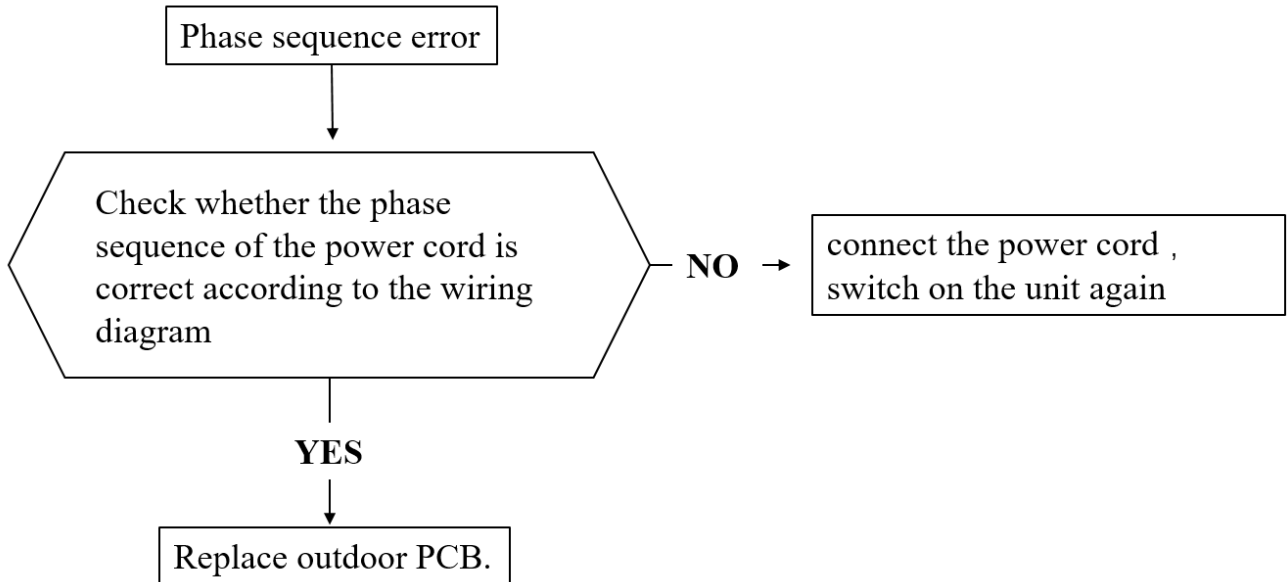

6) Lack of phase:

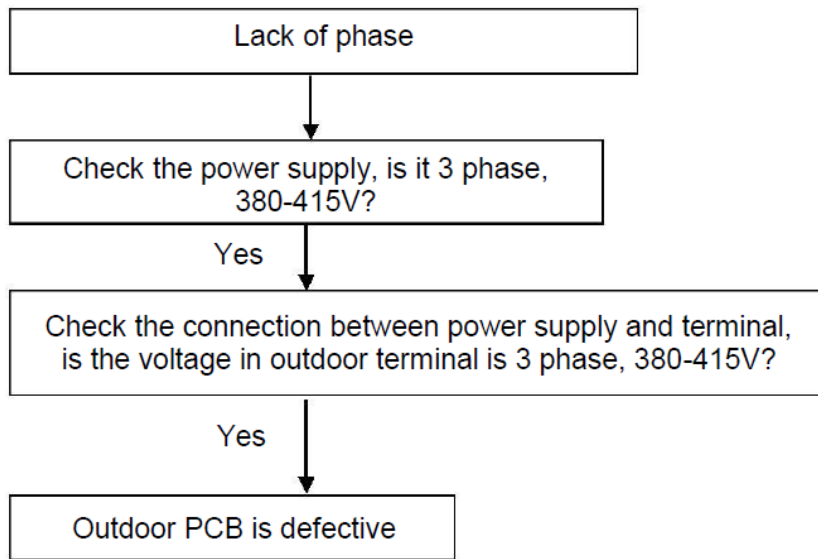

**e.d3—Full-water malfunction**

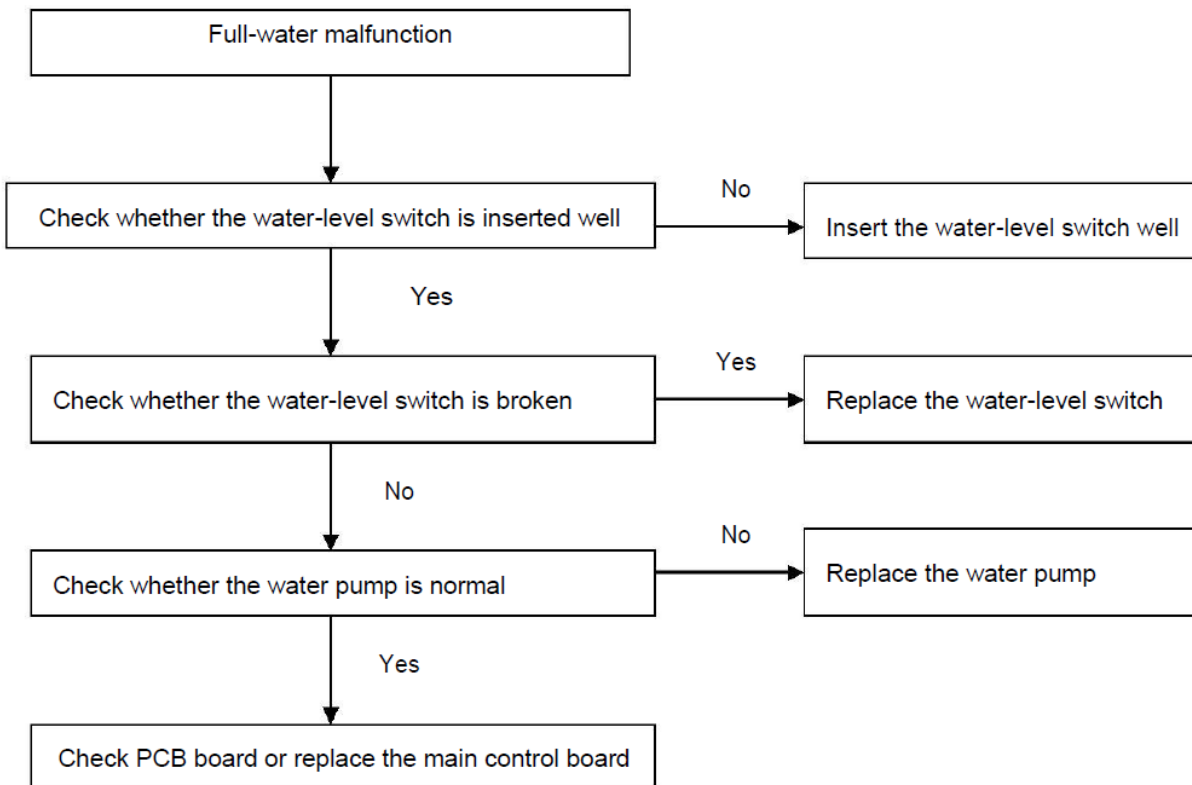

**f. Ed—EEPROM malfunction**

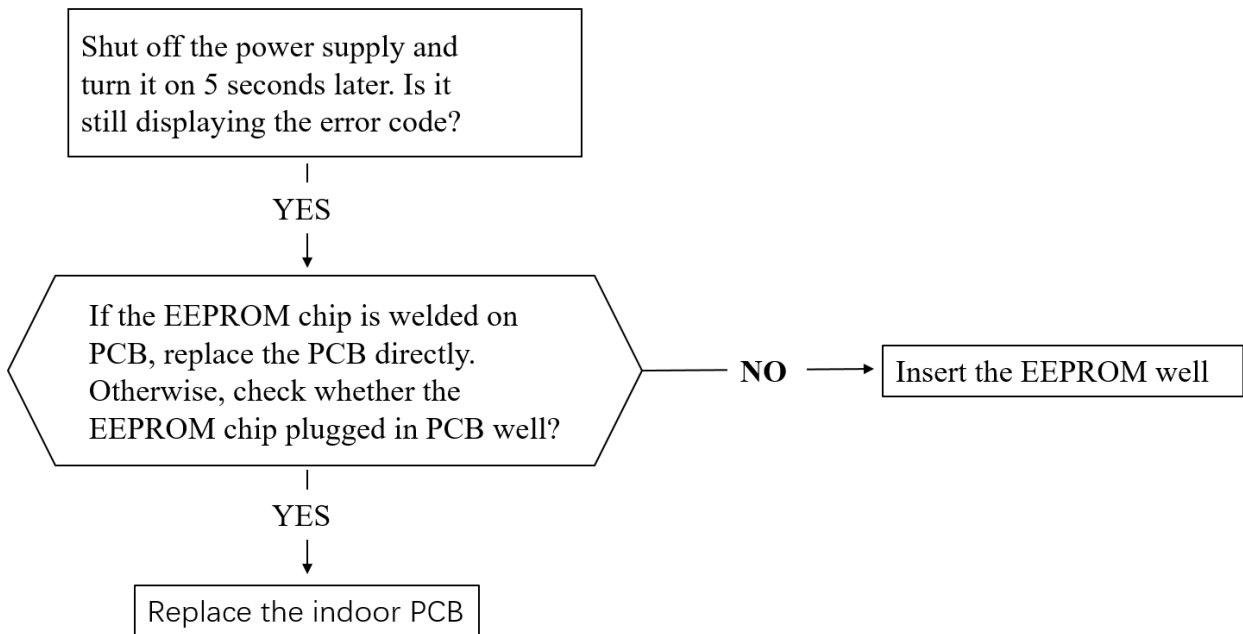

**g. C5—Bad communication between indoor PCB & wire controller**

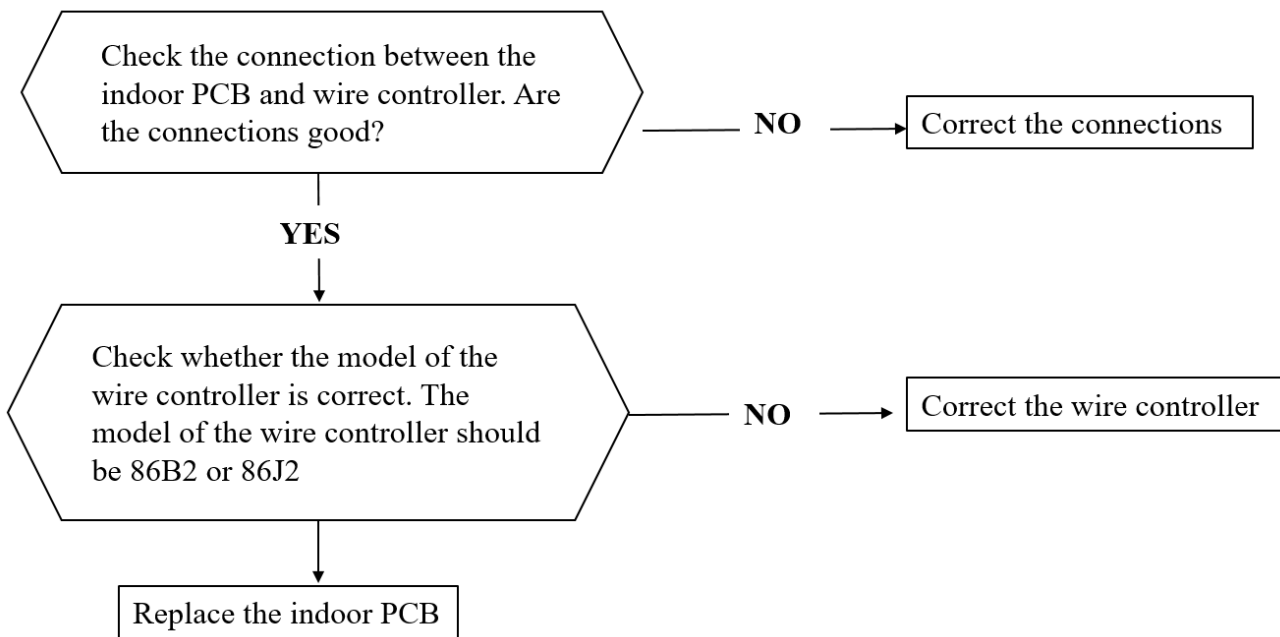

# Part 4 Installation

## 1. Precaution on Installation

1). Measure the necessary length of the connecting pipe, and make it by the following way.

a. Connect the indoor unit at first, then the outdoor unit. Bend the tubing in proper way. Do not harm them.

*Specially Notice the pipe length/height/dimension of each capacity.*

### Maximum pipe length

| Model                   | Max. Length | Max. Elevation |
|-------------------------|-------------|----------------|
| 12000 Btu/h             | 25m         | 15m            |
| 18,000Btu/h             | 25m         | 15m            |
| 24,000Btu/h             | 30m         | 15m            |
| 36,000Btu/h             | 30m         | 20m            |
| 48,000Btu/h~60,000Btu/h | 50m         | 30m            |

### Piping sizes

| Model                   | Liquid(mm) | Gas(mm) |
|-------------------------|------------|---------|
| 12000 Btu/h             | 6.35       | 12.70   |
| 18,000Btu/h             | 6.35       | 12.70   |
| 24,000Btu/h             | 9.52       | 15.88   |
| 36,000Btu/h~60,000Btu/h | 9.52       | 19.05   |

### CAUTIONS

- Daub the surfaces of the flare pipe and the joint nuts with frozen oil, and wrench it for 3~4 rounds
- With hands before fasten the flare nuts.
- Be sure to use two wrenches simultaneously when you connect or disconnect the pipes.

| Pipe gauge | Tightening torque             | Flare dimension A |      | Flare shape |
|------------|-------------------------------|-------------------|------|-------------|
|            |                               | Min (mm)          | Max  |             |
| Φ6.4       | 15~16N.m<br>(153~ 163 kgf.cm) | 8.3               | 8.7  |             |
| Φ9.5       | 25~26N.m<br>(255~ 265kgf.cm)  | 12.0              | 12.4 |             |
| Φ12.7      | 35~36N.m<br>(357~367kgf.cm)   | 15.4              | 15.8 |             |
| Φ15.9      | 45~47N.m<br>(459~480 kgf.cm)  | 18.6              | 19.1 |             |
| Φ19.1      | 65~67N.m<br>(663~684kgf.cm)   | 22.9              | 23.3 |             |

b. The stop valve of the outdoor unit should be closed absolutely (as original state). Every time you connect it, first loosen the nuts at the part of stop valve, then connect the flare pipe immediately (in 5 minutes). If the nuts have been loosened for a long time, dusts and other impurities may enter the pipe system and may cause malfunction later. So please expel the air out of the pipe with refrigerant before connection.

c. Expel the air after connecting the refrigerant pipe with the indoor unit and the outdoor unit. Then fasten the nuts at the repair-points.

### 2) Locate The Pipe

- a. Drill a hole in the wall (suitable just for the size of the wall conduit), then set on the fittings such as the wall conduit and its cover.
  - b. Bind the connecting pipe and the cables together tightly with binding tapes. Do not let air in, which will cause water leakage by condensation.
  - c. Pass the bound connecting pipe through the wall conduit from outside. Be careful of the pipe allocation to do no damage to the tubing.
- 3) Connect the pipes.
  - 4) Then, open the stem of stop valves of the outdoor unit to make the refrigerant pipe connecting the indoor unit with the outdoor unit in fluent flow.
  - 5) Be sure of no leakage by checking it with leak detector or soap water.
  - 6) Cover the joint of the connecting pipe to the indoor unit with the soundproof / insulating sheath (fittings), and bind it well with the tapes to prevent leakage.

## 2. Vacuum Dry and Leakage Checking

2.1 Vacuum Dry: use vacuum pump to change the moisture (liquid) into steam (gas) in the pipe and discharge it out of the pipe to make the pipe dry. Under one atmospheric pressure, the boiling point of water (steam temperature) is  $^{\circ}\text{C}$ . Use vacuum pump to make the pressure in the pipe near vacuum state, the boiling point of water falls relatively. When it falls under outdoor temperature, the moisture in the pipe will be vaporized.

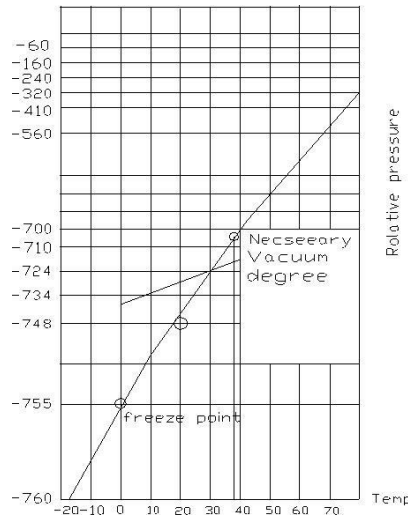

### 2.2 Vacuum dry procedure

There are two methods of vacuum dry due to different construction environment: common vacuum dry, special vacuum dry.

#### ①. Common vacuum dry procedure

- Vacuum dry (for the first time)---connect the all-purpose detector to the inlet of liquid pipe and gas pipe, and run the vacuum pump more than two hours (the vacuum pump should be below  $-755\text{mmHg}$ )
- If the pump can't achieve below  $-755\text{mmHg}$  after pumping 2 hours, moisture or leakage point will still exist in the pipe. At this time, it should be pumped 1 hour more.
- If the pump can't achieve  $-755\text{mmHg}$  after pumping 3 hours, please check if there are some leakage points.
- Vacuum placement test: place 1 hour when it achieves  $-755\text{mmHg}$ , pass if the vacuum watch shows no rising. If it rises, it shows there's moisture or leakage point.
- Vacuuming from liquid pipe and gas pipe at the same time.
- Sketch map of common vacuum dry procedure.

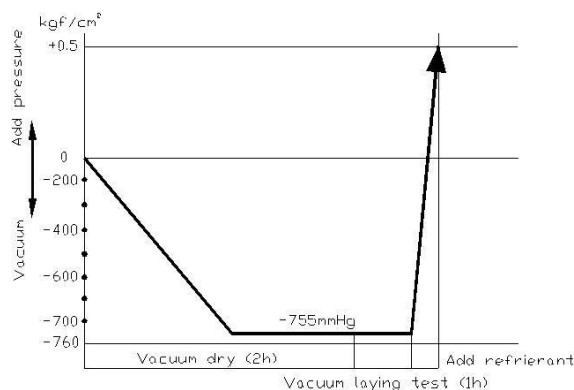

#### ②. Special vacuum dry procedure

- This vacuum dry method is used in the following conditions:
- There's moisture when flushing the refrigerant pipe.
- Rainwater may enter into the pipe.
- Vacuum dry for the first time ..... 2h pumping

③. Vacuum destroy for the second time ..... Fill nitrogen to 0.5Kgf/cm<sup>2</sup>

Because nitrogen is for drying gas, it has vacuum drying effect during vacuum destroy. But if the moisture is too much, this method can't dry thoroughly. So, please pay more attention to prevent water entering and forming condensation water.

④. Vacuum dry for the second time ..... 1h pumping

Determinant: Pass if achieving below -755mmHg. If -755mmHg can't be achieved in 2h, repeat procedure ③ and ④.

⑤. Vacuum placing test ..... 1h

⑥. Sketch map of special vacuum dry procedure

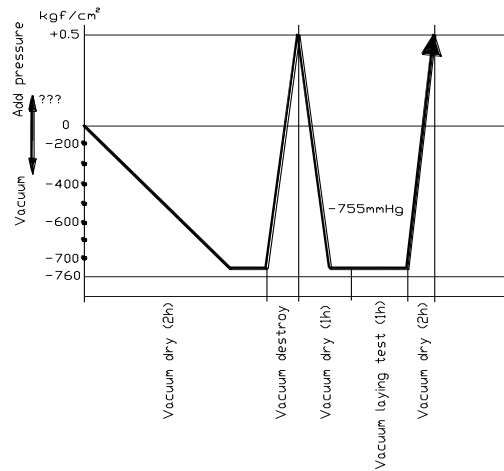

### 3. Additional Refrigerant Charge

#### Caution

- Refrigerant cannot be charged until field wiring has been completed.
- Refrigerant may only be charged after performing the leak test and the vacuum pumping.
- When charging a system, care shall be taken that its maximum permissible charge is never exceeded, in view of the danger of liquid hammer.
- Charging with an unsuitable substance may cause explosions and accidents, so always ensure that the appropriate refrigerant is charged.
- Refrigerant containers shall be opened slowly.
- Always use protective gloves and protect your eyes when charging refrigerant.

The outdoor unit is factory charged with refrigerant. Calculate the added refrigerant according to the diameter and the length of the liquid side pipe of the outdoor unit/indoor unit

| R(g) \ D(mm)                                      | φ6.4        | Φ9.5        | Φ12.7        |
|---|-------------|-------------|--------------|
| L(m)  |             |             |              |
| Less than 5m (One-way)                            | —           | —           | —            |
| Added Refrigerant(R410A)<br>When Over 5m(One-way) | 22g/m*(L-5) | 54g/m*(L-5) | 110g/m*(L-5) |

Remark:

R (g): Additional refrigerant to be charged

L (m): The length of the refrigerant pipe (one-way)

D (mm): Liquid side piping diameter

## 4. Water Drainage

### 4.1 Gradient and Supporting

4.1.1 Keep the drainpipe sloping downwards at a gradient of at least 1/100. Keep the drainpipe as short as possible and eliminate the air bubble.

4.1.2 The horizontal drainpipe should be short. When the pipe is too long, a prop stand must be installed to keep the gradient of 1/100 and prevent bending. Refer to the following table for the specification of the prop stand.

|               | Diameter | Distance between the prop stands |
|---------------|----------|----------------------------------|
| Hard PVC pipe | 25~40mm  | 1~1.5m                           |

#### 4.1.3. Precautions

- ① The diameter of drainpipe should meet the drainage requirement at least.
- ② The drainpipe should be heat-insulated to prevent atomization.
- ③ Drainpipe should be installed before installing indoor unit. After powering on, there is some water in water-receiver plate. Please check if the drain pump can operate correctly.
- ④ All connection should be firm.
- ⑤ Wipe color on PVC pipe to note connection.
- ⑥ Climbing, horizontal and bending conditions are prohibited.
- ⑦ The dimension of drainpipe can't less than the connecting dimension of indoor drainpipe.
- ⑧ Heat-insulation should be done well to prevent condensation.
- ⑨ Indoor units with different drainage type can't share one convergent drainpipe.

### 4.2 Drainpipe Trap

4.2.1 If the pressure at the connection of the drainpipe is negative, it needs to design drainpipe trap.

4.2.2 Every indoor unit needs one drainpipe trap.

4.2.3 A plug should be designed to do cleaning.

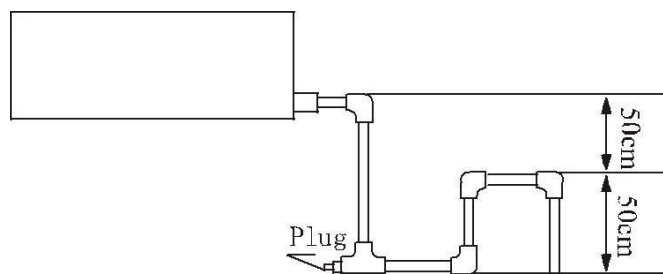

### 4.3 Upwards drainage (drain pump)

For Four-way cassette(compact)

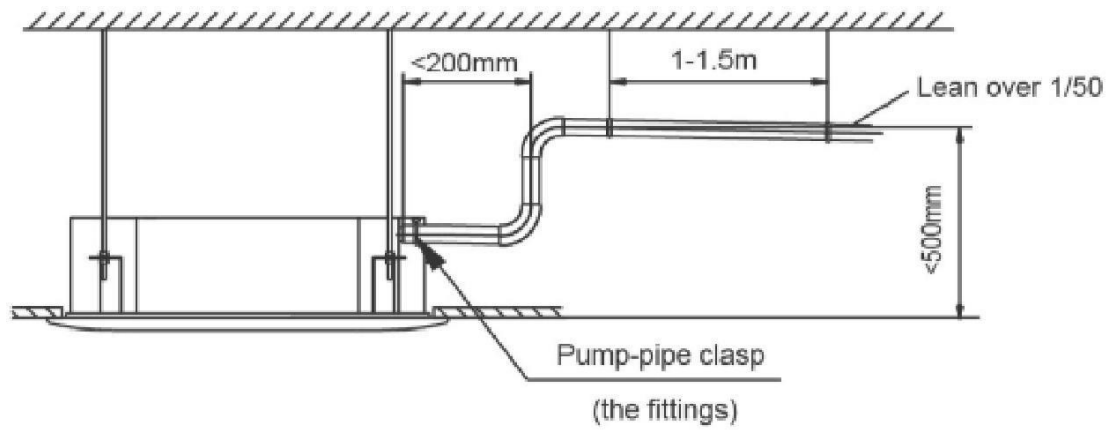

#### For Four-way cassette

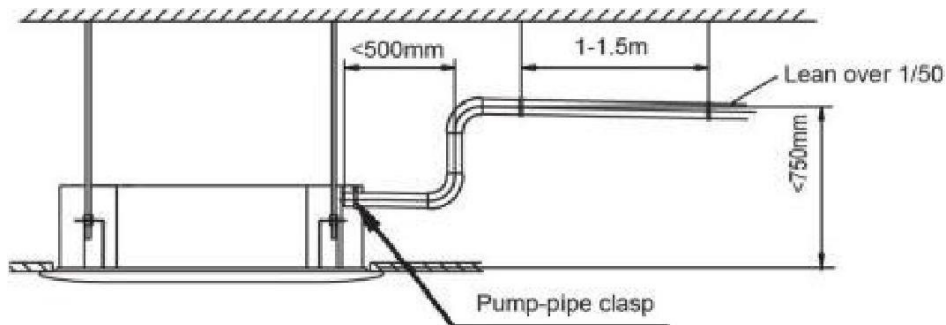

### 4.4 Convergent drainage

4.4.1 The number of indoor units should be as small as possible to prevent the traverse main pipe overlong.

4.4.2 Indoor unit with drain pump and indoor unit without drain pump should be in different drainage system.

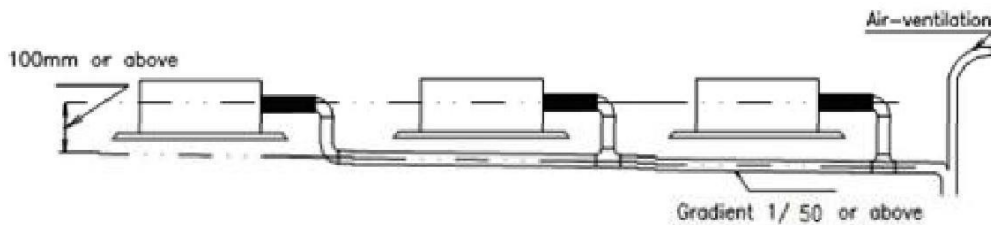

#### 4.4.3 Selecting the diameter

Number of connecting indoor units → Calculate drainage volume → Select the diameter

Calculate allowed volume = Total cooling capacity of indoor units (HP) × 2 (l/hr)

|          | Allowed volume(lean 1/50) (l/hr) | I.D. (mm) | Thick |
|----------|----------------------------------|-----------|-------|
| Hard PVC | ~ ≤ 14                           | ∅ 25      | 3.0   |
| Hard PVC | 14 < ~ ≤ 88                      | ∅ 30      | 3.5   |
| Hard PVC | 88 < ~ ≤ 334                     | ∅ 40      | 4.0   |
| Hard PVC | 175 < ~ ≤ 334                    | ∅ 50      | 4.5   |
| Hard PVC | 334 < ~                          | ∅ 80      | 6.0   |

### 4.5 drainage test

#### 4.5.1 Drainage without drain pump

After finishing drainpipe installation, pour some water into the water receiver plate to check if the water flows smoothly.

#### 4.5.2 Drainage with drain pump

① Poke the Water Level Switch, remove the cover, use water pipe to pour 2000ml water into the water receipt plate through the water inlet.

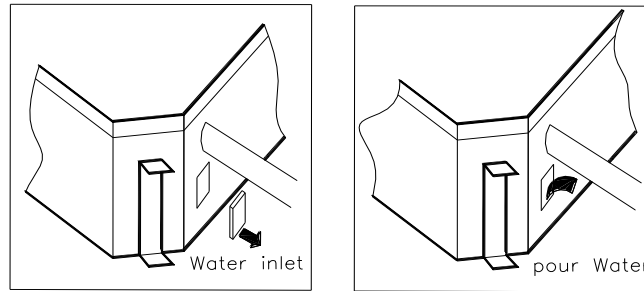

② Turn on the power to Cooling operation. Check the pump's operation and switch on the Water Level Switch. Check the pump's sound and look into the transparent hard pipe in the outlet at the same time to check if the water can discharge normally.

③ Stop the air conditioner running, turn off the power, and put back the cover.

- Stop the air conditioner. After 3 minutes, check if it has abnormality. If the collocation of drainpipes is illogical, the water will flow back overfull, which will cause the alarm lamp flashes, even overflow from the water receipt plate.
- Keep on pouring water until it gives an alarm signal for high water level, check if the pump drains water at once. If the water level can't fall below the alarmed water level after 3 minutes, the air conditioner will stop. Turn off the power and drain the remained water, and then turn on the air conditioner.

Note: the drain stuff in the main water receipt plate is for maintenance. Stuff up the drain stuff to prevent water leakage.

# 5. Insulation Work

## 5.1 Insulation material and thickness

### 5.1.1. Insulation material

Insulation material should adopt the material which is able to endure the pipe's temperature: no less than 70°C in the high-pressure side, no less than 120°C in the low-pressure side (For the cooling type machine, no requirements at the low-pressure side.)

◆ Example: Heat pump type----Heat-resistant Polyethylene foam (withstand above 120°C)

Cooling only type----Polyethylene foam (withstand above 100°C)

### 5.1.2. Thickness choice for insulation material

Insulation material thickness is as follows:

|                  | Pipe diameter (mm)    | Adiabatic material thickness |
|------------------|-----------------------|------------------------------|
| Refrigerant pipe | Φ6.4—Φ25.4            | 10mm                         |
|                  | Φ28.6—Φ38.1           | 15mm                         |
| Drainage pipe    | Inner diameterΦ20—Φ32 | 6mm                          |

## 5.2 Refrigerant pipe insulation

### 5.2.1. Work Procedure

- ① Before laying the pipes, the non-jointing parts and non-connection parts should be heat insulated.
- ② When the gas proof test is eligible, the jointing area, expanding area and the flange area should be heat insulated

### 5.2.2. Insulation for non-jointing parts and non-connection parts

| wrong   | right                                |                                       |
|---|--------------------------------------|---------------------------------------|
| Gas pipe and liquid pipe should not be put together to insulate | Insulate the gas pipe (cooling only) | Insulate the gas pipe and liquid pipe |
|   |                                      |                                       |

For construction convenience, before laying pipes, use insulation material to insulate the pipes to be deal with, at the same time, at two ends of the pipe, remain some length not to be insulated, in order to be welded and check the leakage after laying the pipes.

### 5.2.3. Insulate for the jointing area, expanding area and the flange area

- ① Insulate for the jointing area, expanding area and the flange area should be done after checking leakage of the pipes
- ② Make sure there's no clearance in the jointing part of the accessorial insulation material and local preparative insulation material.

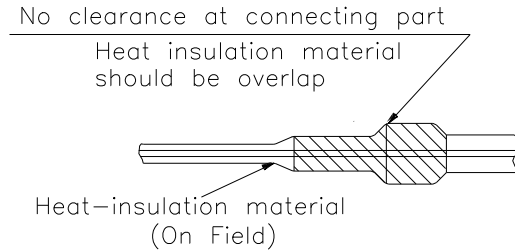

## 5.3 Drainage pipe insulation

The connection part should be insulated, or else water will be condensing at the non-insulation part.

## 5.4 Note

5.4.1 The jointing area, expanding area and the flange area should be heat insulated after passing the pressure test

5.4.2 The gas and liquid pipe should be heat insulated individually, the connecting part should be heat insulated individually.

5.4.3 Use the attached heat-insulation material to insulate the pipe connections (pipes' tie-in, expand nut ) of the indoor unit

## 6. Test Operation

**(1) The test operation must be carried out after the entire installation has been completed.**

**(2) Please confirm the following points before the test operation.**

- The indoor unit and outdoor unit are installed properly. Tubing and wiring are correctly completed.
- The refrigerant pipe system is leakage-checked. The drainage is unimpeded.
- The ground wiring is connected correctly.
- The length of the tubing and the added stow capacity of the refrigerant have been recorded. The power voltage fits the rated voltage of the air conditioner.
- There is no obstacle at the outlet and inlet of the outdoor and indoor units.
- The gas-side and liquid-side stop valves are both opened. The air conditioner is pre-heated by turning on the power.

**(3) According to the user's requirement, install the remote controller when the remote controller's signal can reach the indoor unit smoothly.**

**(4) Test operation**

Set the air conditioner under the mode of "COOLING" with the remote controller, and check the following points.

### **Indoor unit**

- Whether the switch on the remote controller works well.
- Whether the buttons on the remote controller works well.
- Whether the air flow louver moves normally.
- Whether the room temperature is adjusted well.
- Whether the indicator lights normally.
- Whether the temporary buttons works well.
- Whether the drainage is normal.
- Whether there is vibration or abnormal noise during operation.

### **Outdoor unit**

- Whether there is vibration or abnormal noise during operation.
- Whether the generated wind, noise, or condensed of by the air conditioner have influenced your neighborhood.
- Whether any of the refrigerant is leaked.

# Part 5 Control





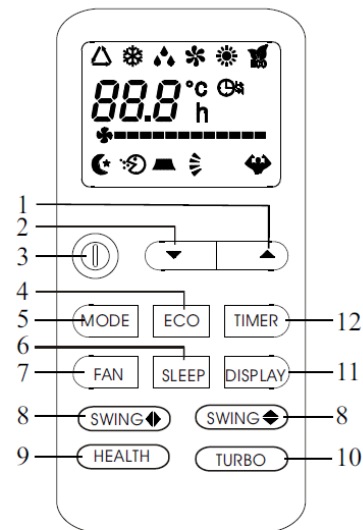













## 1. Wireless remote controller

| No. | Button      | Function  |
|-----|-------------|---|
| 1   | ▲ (TEMP UP) | Increase the temperature or time by 1 unit  |
| 2   | ▼ (TEMP DN) | Decrease the temperature or time by 1 unit  |
| 3   | ON/OFF      | To switch the conditioner on and off.   |
| 4   | ECO         | In cooling mode,press this button ,the temperature will increase 2℃ on the base of setting temperature<br>In heating mode, press this button, the temperature will decrease 2℃ on the base of setting temperature |
| 5   | MODE        | To select the mode of operation   |
| 6   | SLEEP       | To activate the function “SLEEP”  |
| 7   | FAN         | To select the fan speed of auto/low/mid/high  |
| 8   | SWING       | To activate or deactivate of the movement of the “DEFLECTORS” .   |
| 9   | HEALTHY     | To switch - on /off HEALTHY funtion.It is a button which controls the ionizer or plasma generator only for inverter type.   |
| 10  | TURBO       | In cooling mode, press this button, the unit will give the maximum cooling temperature with 16℃<br>In heating mode, press this button, the unit will give the maximum heating temperature with 31℃                |
| 11  | DISPLAY     | To switch on/off the LED display (if present)   |
| 12  | TIMER       | To set automatic switching-on/off   |
| 13  | SUPER       | In cooling mode, press this button, the unit will give the maximum cooling temperature with 16℃<br>In heating mode, press this button, the unit will give the maximum heating temperature with 31℃                |



- The outlook and some function of remote control may vary according to the model.
- The shape and position of buttons and indicators may vary according to the model, but their function is the same.
- The unit confirms the correct reception of each press button with a beep.

## Remote control DISPLAY Meaning of symbols on the liquid crystal display

| No. | Symbols   | Meaning                      |
|-----|---|------------------------------|
| 1   |    | FEEL mode indicator          |
| 2   |    | COOLING indicator            |
| 3   |    | DEHUMIDIFYING indicator      |
| 4   |    | FAN ONLY OPERATION indicator |
| 5   |    | HEATING indicator            |
| 6   |    | TIMER OFF indicator          |
| 7   |    | TIMER ON indicator           |
| 8   |    | AUTO FAN indicator           |
| 9   |    | LOW FAN SPEED indicator      |
| 10  |    | MIDDLE FAN SPEED indicator   |
| 11  |    | HIGH FAN SPEED indicator     |
| 12  |    | SLEEP indicator              |
| 13  |   | SUPER indicator              |
| 14  |  | HEALTHY indicator            |
| 15  |  | ECO indicator                |
| 16  |  | BATTERY indicator            |
| 17  |  | BATTERY indicator            |
| 18  |  | CLOCK indicator              |

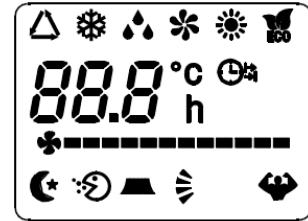

## 2. Wired remote controller

### 2.1 An Introduction to Wire Controller

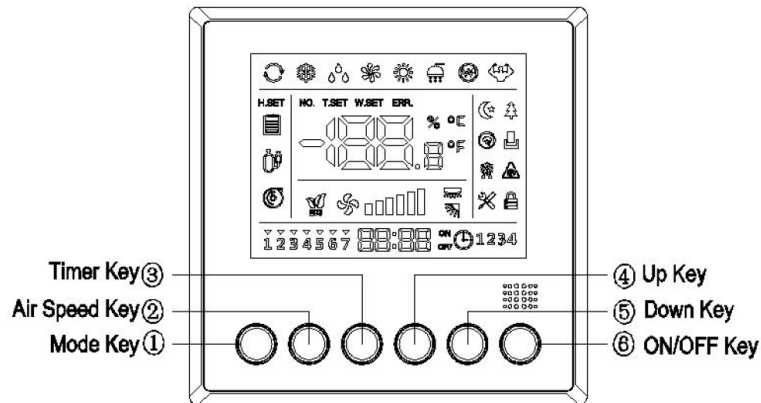

#### Description of Icons or Symbols

|           |                           |             |                     |            |                   |  |                 |
|-----------|---------------------------|-------------|---------------------|------------|-------------------|--|-----------------|
|           | Sleep                     |             | Fresh               |            | Door Card         |  | Defrost         |
|           | Anti-freeze               |             | Set                 |            | Child Lock        |  | Economic        |
|           | Up/Down Swing             |             | Left/Right Swing    |            | Degree centigrade |  | Fahrenheit      |
|           | Electric                  | <i>ERR.</i> | Error               |            | Water Level       |  | Water Pump Sign |
| <i>W.</i> | Current Water Temperature | <i>T.</i>   | Ambient Temperature | <i>SET</i> | Set Temperature   |  | Compressor Sign |
| <i>ON</i> | Timer ON                  | <i>OFF</i>  | Timer OFF           |            |                   |  |                 |

Remark: If an icon goes on, it means “ON”; if such icon goes off, it means “OFF”.

#### Dial Setting

| Definition | SW1-1 | SW1-2 | Description |
|------------|-------|-------|-------------|
| Reserve    | ON    | -     | /           |
|            | OFF   | -     | /           |
| Reserve    | -     | ON    | /           |
|            | -     | OFF   | /           |

### 2.2 Initial Power-on

1.1. It is necessary to initially power the wire controller on for self-check wherein all the icons or symbols go on for 3 seconds. During such period, all the key and remote controller operations are invalid.

1.2. The wire controller is without the power-down memory function by default. If a user needs to use the power-down memory function, such user can see the detailed parameters corresponding to “P1” in Section 7.2 - -- Parameter Setting.

### 2.3 Key Description

#### 2.3.1 [ON/OFF] Key

2.3.1.1. Press the [ON/OFF] key once to start the controller; press the [ON/OFF] key once again to stop the controller.

### 2.3.1.2. Liquid Crystal Self-check:

Press the [ON/OFF] key to power the controller on for 5 seconds and then release such key; the controller enters self-check at the moment. The controller executes the liquid crystal self-check in the following sequence: After the buzzer short sounds once, the following outputs successively motion (wherein the liquid crystal successively goes on from left to right and then go off.) After that, the controller exits from the self-check.

Notes: 1. The controller exits from the self-check status after it is powered off in the self-check status.

2. All the keys are invalid during the self-check.

### 2.3.2. [Mode] Key

#### 2.3.2.1. Mode Switch

On the startup interface, press the [Mode] key once when the selected mode icon normally goes on and other icons go off. The switch sequence is as shown in the right picture.

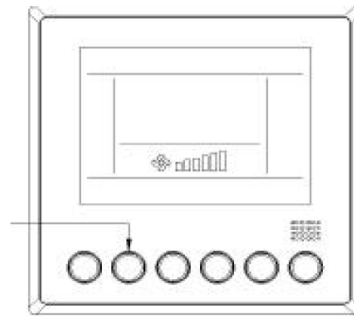

The refrigeration machine is without the “Heat” icon.

Automatic Mode: The controller with the power-down memory function can be powered on again after being powered down, re-judge the temperature and then re-execute the automatic mode; if the power-down memory function is not started, the controller will enter the standby mode.

#### 2.3.2.2. Function Setting

On the startup interface, long press the [Mode] key for over 5 seconds to enter the function setting interface; short press the [Mode] key when the selected function icon twinkles with the frequency of 1Hz and other icons act as per the actual status (if the status is ON, the icons normally go on; otherwise, the icons go off.)

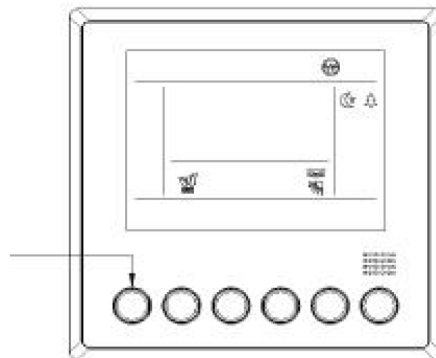

### 2.3.3. [▲]/[▼] Key

2.3.3.1 On the startup interface, press the [▲]/[▼] key once to set the temperature increase or decrease by 0.5°C ;

#### 2.3.3.2 Forced Defrosting

On the startup interface, set the wire controller to be in the heating mode and at the temperature of 16°C, and then finish the following 6 keys of operations within 5 seconds:

“[▲]→[▼]→[▲]→[▼]→[▲]→[▼]”. At the moment, the system successfully enters the forced defrosting and then the

buzzer long beeps once.

### 2.3.4 [Air Speed] Key

On the startup interface, press the [Air Speed] key once, the selected air speed icon normally goes on and other icons go off wherein the air speed switches in the cyclic sequence of low air speed → intermediate air speed → high air speed

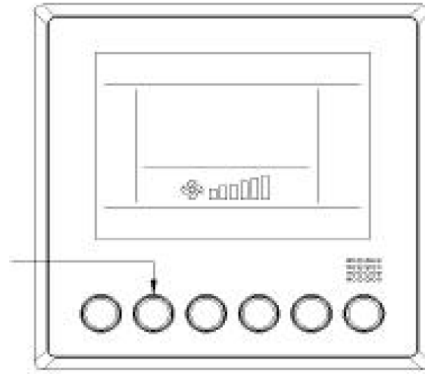

- When the wire controller is initially powered on, its default air speed is low and the icon of low air speed is displayed.
- When being in the dehumidifying mode, the wire controller does not respond to any operation of the [Air Speed] key wherein the air speed cannot be adjusted, the default air speed is low and the icon of low air speed normally goes on.
- When the wire controller is at the time of automatic air, the air speed icon is successively displayed in the dynamic and cyclic sequence of low air speed intermediate air speed high air speed low air speed.
- If the air speed is of individual backup, the wire controller will display the last set air speed of the corresponding mode when it enters the same mode next time.

### 2.3.5 [Timer] Key

2.3.5.1 Continuously press the [Timer] key for over 5 seconds to enter the clock setting interface (See Chapter 5--- Clock Setting for details).

2.3.5.2 Press the [Timer] key once to enter the timer setting interface (See Chapter 6---Timer Setting for details).

## 2.4. Auxiliary Functions

### 2.4.1. Child Lock

1. On the startup or shutdown interface, simultaneously press the [▲] and [▼] keys for over 5 seconds to enable the child lock when the child lock icon normally goes on.
2. When the child lock is valid, the operations of other keys are invalid but the icons twinkle with the frequency of 1Hz.

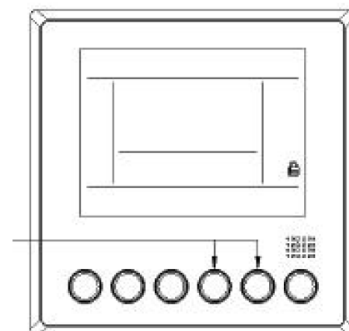

## 2.5. Clock Setting

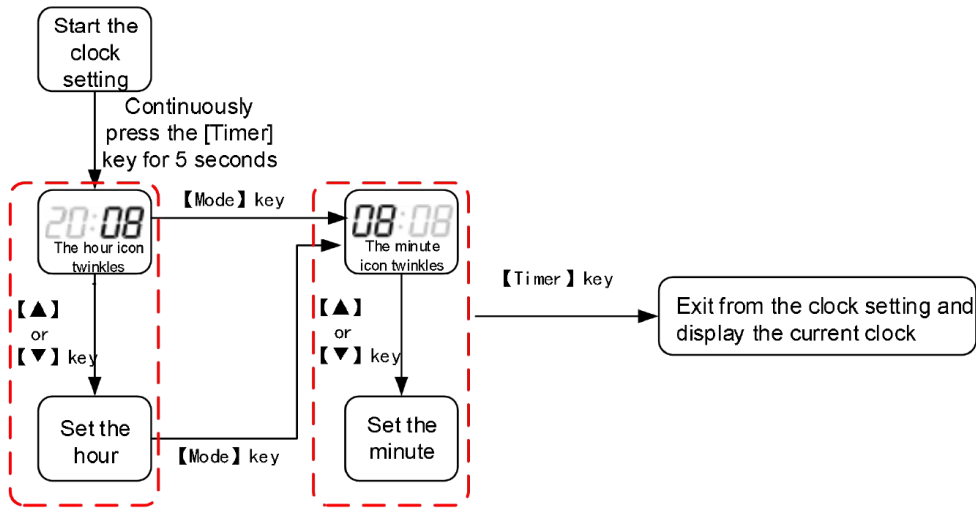

Set the period by pressing the [Timer] key and then exit from the clock setting with such setting saved;

Set the period by pressing the [ON/OFF] or [Mode] key and then exit from the clock setting with such setting not saved; Set the status and if there are no key operations for 15 consecutive seconds, exit from the clock setting with such setting not saved.

## 2.6. Timer Setting

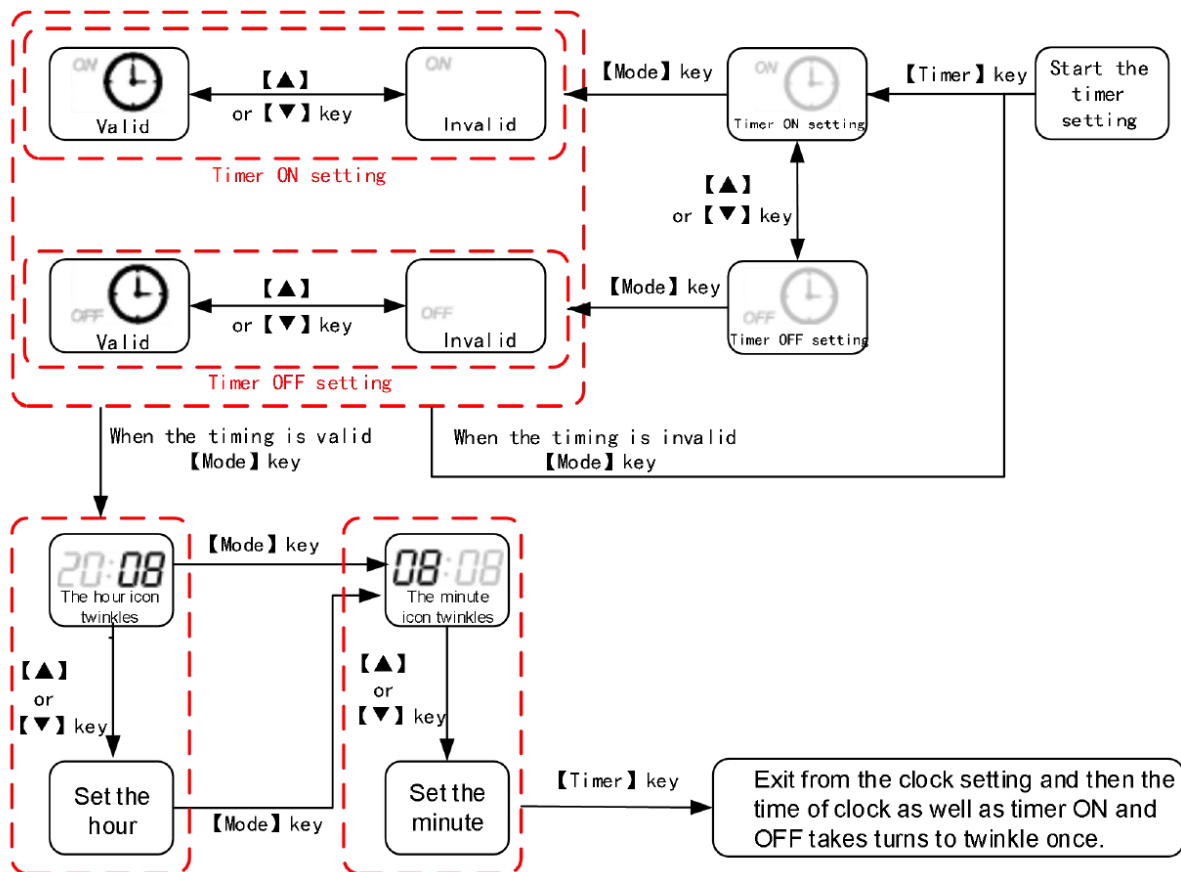

Set the period by pressing the [Timer] key and then exit from the clock setting with such setting saved;

Set the period by pressing the [ON/OFF] or [Mode] key and then exit from the clock setting with such setting not saved; Set the status and if there are no key operations for 15 consecutive seconds, exit from the clock setting with such setting not saved.

## 2.7. Parameter Query/Setting

### 2.7.1 Parameter Query

- Continuously press the “[Mode]+[▲]” combination keys for 5 seconds to automatically enter the parameter query interface when the “Time Area-Hour” icon twinkles and displays the “Parameter Code” and “Temperature Area” displays the current “Parameter Value” corresponding to such “Parameter Code”.
- When the parameter code twinkles, press the [▲] or [▼] key to switch the parameter code.

| Parameter Code | Area Display   | Parameter Name   | Query the Current Parameter |                  | Query Range |
|----------------|----------------|--|-----------------------------|------------------|-------------|
|                |                |  | Value to Query              | Area Display     |             |
| 01             | Time Area-Hour | Indoor ambient temperature                                 | Current value               | Temperature Area | -30~150     |
| 02             | Time Area-Hour | Aperture of expansion valve of the indoor unit             | Current value               | Temperature Area | 0~500       |
| 03             | Time Area-Hour | Temperature at the inlet of evaporator of the              | Current value               | Temperature Area | -30~150     |
| 04             | Time Area-Hour | Temperature in the middle of evaporator of                 | Current value               | Temperature Area | -30~150     |
| 05             | Time Area-Hour | Temperature at the outlet of evaporator of the indoor unit | Current value               | Temperature Area | -30~150     |
| 06             | Time Area-Hour | Engineering number of the indoor unit                      | Current value               | Temperature Area | /           |
| 07             | Time Area-Hour | IP address of the indoor unit                              | Current value               | Temperature Area | /           |
| E1             | Time Area-Hour | Historical Error 1   | Err+**                      | Temperature Area |             |
| E2             | Time Area-Hour | Historical Error 2   | Err+**                      | Temperature Area |             |
| E3             | Time Area-Hour | Historical Error 3   | Err+**                      | Temperature Area |             |
| E4             | Time Area-Hour | Historical Error 4   | Err+**                      | Temperature Area |             |
| E5             | Time Area-Hour | Historical Error 5   | Err+**                      | Temperature Area |             |

### 2.7.2 Parameter Setting

- Continuously press the “[Mode]+[▼]” combination keys for 5 seconds to automatically enter the parameter setting interface when the “Time Area-Hour” icon twinkles and displays the “Parameter Code” and “Temperature Area” displays the current “Parameter Value” corresponding to such “Parameter Code”.
- When the parameter code twinkles, press the [▲] or [▼] key to switch the “Parameter Code”; press the [Mode] key to stop the “Parameter Code” from twinkling and enters the “Parameter Value” changing interface when the “Parameter Value” twinkles.
- When the parameter value twinkles, press the [▲] or [▼] key to change the “Parameter Value”; press the [Mode] key to save the “Parameter Value” and return to the “Parameter Code” twinkling interface.

| ● Parameter Code |                |  | Query the Current Parameter |                          | Query Range              |
|------------------|----------------|--|-----------------------------|--------------------------|--------------------------|
| Parameter Code   | Area Display   | Parameter Name   | Value to                    | Area Display             |                          |
| P1               | Time Area-Hour | The indoor unit corresponding to the wire controller is the indoor unit in the master mode | S<br>L                      | Temperature Display Area | SL: From the indoor unit |

|    |                    |   |     |                             |                                      |
|----|--------------------|---|-----|-----------------------------|--------------------------------------|
| P2 | Time Area- Hour    | Clearing Away<br>the Master Indoor Unit from<br>the Set                               | 00  | Temperature Display         | 00: No action                        |
| P3 | Time Area- Hour    | Address Setting of Two-wire<br>Controller   | 01  | Temperature Display         | 01: Upper computer of<br>RS485 trunk |
| P5 | Time Area- Hour    | Power-down memory mode  | Off | Temperature Display         | On: Valid                            |
|    |                    |   | on  |                             | Off: Invalid                         |
| P6 | Time Area- Hour    | Temperature Unit Conversion   | °C  | Temperature Display         | C: degree centigrade                 |
|    |                    |   | °F  |                             |                                      |
| P7 | Time Area- Hour    | Selection of<br>Ambient Temperature<br>Sensing Bag                                    | IL  | Temperature Display         | /                                    |
| P8 | Time Area- Hour    | Modification<br>Value of<br>Return-air<br>Temperature Sensing<br>Bag(Cooling、<br>Dry) | 00  | Temperature Display         | -15°C~15°C                           |
|    |                    | Modification<br>Value of<br>Return-air<br>Temperature<br>Sensing<br>Bag(Heating)      |     |                             |                                      |
| P9 | Time Area-<br>Hour | Modification<br>Value of<br>Return-air<br>Temperature<br>Sensing<br>Bag(Heating)      | 00  | Temperature Display         | -15°C~15°C                           |
| PA | Time Area- Hour    | Start-up default setting  | 00  | Temperature Display<br>Area | 00: Display setting<br>temperature   |
|    |                    |   | 01  |                             | 01: Display ambient<br>temperature   |
| PC | Time Area- Hour    | Fan speed setting   | 03  | Temperature Display         | 03: 3 level speed                    |
|    |                    |   | 07  |                             | 07: 7 level speed                    |
| PF | Time Area- Hour    | Thermal<br>Aggregation Prevention(minute)   | 00  | Temperature Display         | 00~60                                |
| PH | Time Area- Hour    | Maximum<br>Defrosting Duration(minute)  | 15  | Temperature Display         | 00~20                                |

## Annex 1 Parameter Table of Indoor Temperature and Evaporator Temperature Sensor

| T (°C) | Rmin (K Ω) | Rnom (K Ω) | Rmax (K Ω) | T (°C) | Rmin (K Ω) | Rnom (K Ω) | Rmax (K Ω) |
|--------|------------|------------|------------|--------|------------|------------|------------|
| -40    | 370.906    | 388.619    | 407.137    | -3     | 39.418     | 40.376     | 41.352     |
| -39    | 345.908    | 362.171    | 379.162    | -2     | 37.371     | 38.259     | 39.163     |
| -38    | 322.825    | 337.767    | 353.366    | -1     | 35.442     | 36.264     | 37.102     |
| -37    | 301.489    | 315.226    | 329.556    | 0      | 33.623     | 34.385     | 35.160     |
| -36    | 281.749    | 294.386    | 307.558    | 1      | 31.907     | 32.613     | 33.330     |
| -35    | 263.470    | 275.100    | 287.215    | 2      | 30.288     | 30.941     | 31.605     |
| -34    | 246.528    | 257.238    | 268.386    | 3      | 28.759     | 29.364     | 29.979     |
| -33    | 230.812    | 240.679    | 250.942    | 4      | 27.316     | 27.876     | 28.445     |
| -32    | 216.222    | 225.317    | 234.770    | 5      | 25.953     | 26.471     | 26.998     |
| -31    | 202.667    | 211.053    | 219.764    | 6      | 24.665     | 25.145     | 25.632     |
| -30    | 190.063    | 197.799    | 205.830    | 7      | 23.448     | 23.892     | 24.342     |
| -29    | 178.336    | 185.475    | 192.881    | 8      | 22.298     | 22.708     | 23.124     |
| -28    | 167.416    | 174.007    | 180.840    | 9      | 21.210     | 21.590     | 21.974     |
| -27    | 157.242    | 163.330    | 169.636    | 10     | 20.181     | 20.532     | 20.887     |
| -26    | 147.757    | 153.381    | 159.202    | 11     | 19.207     | 19.532     | 19.859     |
| -25    | 138.908    | 144.105    | 149.482    | 12     | 18.286     | 18.586     | 18.888     |
| -24    | 130.648    | 135.452    | 140.419    | 13     | 17.414     | 17.690     | 17.969     |
| -23    | 122.933    | 127.375    | 131.965    | 14     | 16.588     | 16.843     | 17.100     |
| -22    | 115.724    | 119.832    | 124.074    | 15     | 15.806     | 16.041     | 16.278     |
| -21    | 108.983    | 112.783    | 116.705    | 16     | 15.064     | 15.281     | 15.500     |
| -20    | 102.676    | 106.193    | 109.819    | 17     | 14.362     | 14.562     | 14.763     |
| -19    | 96.774     | 100.028    | 103.382    | 18     | 13.696     | 13.880     | 14.065     |
| -18    | 91.246     | 94.259     | 97.361     | 19     | 13.065     | 13.234     | 13.404     |
| -17    | 86.067     | 88.857     | 91.727     | 20     | 12.466     | 12.621     | 12.777     |
| -16    | 81.213     | 83.796     | 86.453     | 21     | 11.898     | 12.041     | 12.184     |
| -15    | 76.661     | 79.054     | 81.512     | 22     | 11.359     | 11.490     | 11.621     |
| -14    | 72.391     | 74.607     | 76.882     | 23     | 10.847     | 10.967     | 11.087     |
| -13    | 68.383     | 70.436     | 72.542     | 24     | 10.361     | 10.471     | 10.580     |
| -12    | 64.620     | 66.521     | 68.472     | 25     | 9.900      | 10.000     | 10.100     |
| -11    | 61.085     | 62.847     | 64.653     | 26     | 9.453      | 9.553      | 9.653      |
| -10    | 57.763     | 59.396     | 61.068     | 27     | 9.029      | 9.128      | 9.228      |
| -9     | 54.641     | 56.153     | 57.702     | 28     | 8.626      | 8.725      | 8.824      |
| -8     | 51.704     | 53.106     | 54.540     | 29     | 8.243      | 8.342      | 8.440      |
| -7     | 48.942     | 50.241     | 51.569     | 30     | 7.880      | 7.977      | 8.075      |
| -6     | 46.342     | 47.546     | 48.776     | 31     | 7.534      | 7.631      | 7.728      |
| -5     | 43.894     | 45.010     | 46.149     | 32     | 7.206      | 7.302      | 7.398      |
| -4     | 41.589     | 42.623     | 43.678     | 33     | 6.894      | 6.988      | 7.084      |

| R25=10K Ω ±1% |           |           | B25/50= 4100K |       |           | 料号: M047-2 |           | 版本: A |  |
|---------------|-----------|-----------|---------------|-------|-----------|------------|-----------|-------|--|
| T(°C)         | Rmin(K Ω) | Rnom(K Ω) | Rmax(K Ω)     | T(°C) | Rmin(K Ω) | Rnom(K Ω)  | Rmax(K Ω) |       |  |
| 34            | 6.597     | 6.690     | 6.785         | 71    | 1.540     | 1.585      | 1.630     |       |  |
| 35            | 6.315     | 6.407     | 6.500         | 72    | 1.487     | 1.530      | 1.575     |       |  |
| 36            | 6.046     | 6.137     | 6.229         | 73    | 1.436     | 1.478      | 1.522     |       |  |
| 37            | 5.790     | 5.880     | 5.970         | 74    | 1.387     | 1.428      | 1.471     |       |  |
| 38            | 5.547     | 5.635     | 5.724         | 75    | 1.340     | 1.380      | 1.422     |       |  |
| 39            | 5.315     | 5.402     | 5.489         | 76    | 1.294     | 1.334      | 1.375     |       |  |
| 40            | 5.094     | 5.179     | 5.266         | 77    | 1.251     | 1.289      | 1.329     |       |  |
| 41            | 4.884     | 4.968     | 5.053         | 78    | 1.209     | 1.247      | 1.286     |       |  |
| 42            | 4.683     | 4.766     | 4.849         | 79    | 1.169     | 1.206      | 1.244     |       |  |
| 43            | 4.492     | 4.573     | 4.655         | 80    | 1.130     | 1.166      | 1.203     |       |  |
| 44            | 4.310     | 4.390     | 4.470         | 81    | 1.093     | 1.128      | 1.164     |       |  |
| 45            | 4.136     | 4.215     | 4.294         | 82    | 1.057     | 1.091      | 1.127     |       |  |
| 46            | 3.971     | 4.047     | 4.125         | 83    | 1.022     | 1.056      | 1.091     |       |  |
| 47            | 3.813     | 3.888     | 3.964         | 84    | 0.989     | 1.022      | 1.056     |       |  |
| 48            | 3.662     | 3.736     | 3.810         | 85    | 0.957     | 0.990      | 1.023     |       |  |
| 49            | 3.518     | 3.590     | 3.663         | 86    | 0.926     | 0.958      | 0.991     |       |  |
| 50            | 3.381     | 3.451     | 3.523         | 87    | 0.897     | 0.928      | 0.960     |       |  |
| 51            | 3.249     | 3.318     | 3.389         | 88    | 0.868     | 0.899      | 0.930     |       |  |
| 52            | 3.124     | 3.192     | 3.260         | 89    | 0.841     | 0.870      | 0.901     |       |  |
| 53            | 3.004     | 3.070     | 3.138         | 90    | 0.814     | 0.843      | 0.873     |       |  |
| 54            | 2.889     | 2.954     | 3.020         | 91    | 0.789     | 0.817      | 0.846     |       |  |
| 55            | 2.779     | 2.843     | 2.908         | 92    | 0.764     | 0.792      | 0.820     |       |  |
| 56            | 2.674     | 2.737     | 2.800         | 93    | 0.741     | 0.768      | 0.796     |       |  |
| 57            | 2.574     | 2.635     | 2.697         | 94    | 0.718     | 0.744      | 0.772     |       |  |
| 58            | 2.478     | 2.538     | 2.598         | 95    | 0.696     | 0.722      | 0.748     |       |  |
| 59            | 2.386     | 2.444     | 2.504         | 96    | 0.675     | 0.700      | 0.726     |       |  |
| 60            | 2.298     | 2.355     | 2.413         | 97    | 0.654     | 0.679      | 0.704     |       |  |
| 61            | 2.214     | 2.269     | 2.326         | 98    | 0.635     | 0.659      | 0.684     |       |  |
| 62            | 2.133     | 2.187     | 2.243         | 99    | 0.615     | 0.639      | 0.663     |       |  |
| 63            | 2.055     | 2.109     | 2.163         | 100   | 0.597     | 0.620      | 0.644     |       |  |
| 64            | 1.981     | 2.033     | 2.087         | 101   | 0.579     | 0.602      | 0.625     |       |  |
| 65            | 1.910     | 1.961     | 2.013         | 102   | 0.562     | 0.584      | 0.607     |       |  |
| 66            | 1.842     | 1.892     | 1.943         | 103   | 0.546     | 0.567      | 0.590     |       |  |
| 67            | 1.776     | 1.825     | 1.875         | 104   | 0.530     | 0.551      | 0.573     |       |  |
| 68            | 1.714     | 1.761     | 1.809         | 105   | 0.514     | 0.535      | 0.556     |       |  |
| 69            | 1.653     | 1.700     | 1.748         |       |           |            |           |       |  |
| 70            | 1.596     | 1.641     | 1.688         |       |           |            |           |       |  |

## Annex 2 Parameter Table of Condenser Temperature Sensor

| MF58 (DO-41) R25=10K $\Omega$ $\pm$ 1% |                   |                   |                   | B25/50=4100 $\pm$ 1% |                   |                   |                   | M323-7 版本: A |
|--|-------------------|-------------------|-------------------|----------------------|-------------------|-------------------|-------------------|--------------|
| T(°C)                                  | Rmin(K $\Omega$ ) | Rnom(K $\Omega$ ) | Rmax(K $\Omega$ ) | T(°C)                | Rmin(K $\Omega$ ) | Rnom(K $\Omega$ ) | Rmax(K $\Omega$ ) |              |
| -40                                    | 311.5143          | 325.8161          | 340.7404          | -3                   | 38.4325           | 39.3562           | 40.2981           |              |
| -39                                    | 291.9141          | 305.1157          | 318.8824          | -2                   | 36.5114           | 37.3696           | 38.2441           |              |
| -38                                    | 273.7720          | 285.9677          | 298.6768          | -1                   | 34.6933           | 35.4905           | 36.3023           |              |
| -37                                    | 256.9550          | 268.2298          | 279.9713          | 0                    | 32.9725           | 33.7128           | 34.4663           |              |
| -36                                    | 241.3453          | 251.7757          | 262.6306          | 1                    | 31.3434           | 32.0307           | 32.7298           |              |
| -35                                    | 226.8376          | 236.4929          | 246.5345          | 2                    | 29.8007           | 30.4387           | 31.0872           |              |
| -34                                    | 213.3378          | 222.2806          | 231.5751          | 3                    | 28.3398           | 28.9318           | 29.5332           |              |
| -33                                    | 200.7613          | 209.0486          | 217.6562          | 4                    | 26.9560           | 27.5052           | 28.0628           |              |
| -32                                    | 189.0326          | 196.7161          | 204.6914          | 5                    | 25.6450           | 26.1543           | 26.6710           |              |
| -31                                    | 178.0833          | 185.2101          | 192.6028          | 6                    | 24.4029           | 24.8750           | 25.3537           |              |
| -30                                    | 167.8519          | 174.4649          | 181.3203          | 7                    | 23.2257           | 23.6632           | 24.1066           |              |
| -29                                    | 158.2829          | 164.4214          | 170.7809          | 8                    | 22.1098           | 22.5151           | 22.9256           |              |
| -28                                    | 149.3258          | 155.0257          | 160.9271          | 9                    | 21.0520           | 21.4273           | 21.8071           |              |
| -27                                    | 140.9347          | 146.2288          | 151.7067          | 10                   | 20.0490           | 20.3964           | 20.7477           |              |
| -26                                    | 133.0681          | 137.9867          | 143.0728          | 11                   | 19.0979           | 19.4193           | 19.7441           |              |
| -25                                    | 125.6881          | 130.2588          | 134.9822          | 12                   | 18.1958           | 18.4929           | 18.7930           |              |
| -24                                    | 118.7600          | 123.0083          | 127.3958          | 13                   | 17.3401           | 17.6147           | 17.8919           |              |
| -23                                    | 112.2521          | 116.2014          | 120.2776          | 14                   | 16.5282           | 16.7818           | 17.0376           |              |
| -22                                    | 106.1354          | 109.8073          | 113.5949          | 15                   | 15.7578           | 15.9919           | 16.2278           |              |
| -21                                    | 100.3832          | 103.7977          | 107.3176          | 16                   | 15.0267           | 15.2426           | 15.4601           |              |
| -20                                    | 94.9711           | 98.1465           | 101.4180          | 17                   | 14.3326           | 14.5316           | 14.7319           |              |
| -19                                    | 89.8764           | 92.8298           | 95.8706           | 18                   | 13.6738           | 13.8570           | 14.0413           |              |
| -18                                    | 85.0785           | 87.8255           | 90.6522           | 19                   | 13.0481           | 13.2167           | 13.3861           |              |
| -17                                    | 80.5581           | 83.1133           | 85.7410           | 20                   | 12.4540           | 12.6090           | 12.7646           |              |
| -16                                    | 76.2974           | 78.6743           | 81.1171           | 21                   | 11.8897           | 12.0320           | 12.1748           |              |
| -15                                    | 72.2800           | 74.4910           | 76.7620           | 22                   | 11.3535           | 11.4841           | 11.6150           |              |
| -14                                    | 68.4907           | 70.5474           | 72.6586           | 23                   | 10.8442           | 10.9638           | 11.0836           |              |
| -13                                    | 64.9152           | 66.8284           | 68.7911           | 24                   | 10.3601           | 10.4695           | 10.5790           |              |
| -12                                    | 61.5405           | 63.3201           | 65.1446           | 25                   | 9.9000            | 10.0000           | 10.1000           |              |
| -11                                    | 58.3543           | 60.0095           | 61.7055           | 26                   | 9.4529            | 9.5538            | 9.6537            |              |
| -10                                    | 55.3453           | 56.8847           | 58.4611           | 27                   | 9.0303            | 9.1298            | 9.2295            |              |
| -9                                     | 52.5028           | 53.9344           | 55.3995           | 28                   | 8.6278            | 8.7268            | 8.8261            |              |
| -8                                     | 49.8169           | 51.1481           | 52.5097           | 29                   | 8.2452            | 8.3436            | 8.4423            |              |
| -7                                     | 47.2782           | 48.5160           | 49.7812           | 30                   | 7.8816            | 7.9792            | 8.0772            |              |
| -6                                     | 44.8784           | 46.0291           | 47.2046           | 31                   | 7.5360            | 7.6327            | 7.7299            |              |
| -5                                     | 42.6091           | 43.6787           | 44.7707           | 32                   | 7.2074            | 7.3031            | 7.3993            |              |
| -4                                     | 40.4628           | 41.4569           | 42.4712           | 33                   | 6.8949            | 6.9895            | 7.0847            |              |

| MF58 (DO-41) R25=10K $\Omega$ $\pm$ 1% |                   |                   |                   | B25/50=4100 $\pm$ 1% |                   |                   |                   | M323-7 版本: A |
|--|-------------------|-------------------|-------------------|----------------------|-------------------|-------------------|-------------------|--------------|
| T (°C)                                 | Rmin(K $\Omega$ ) | Rnom(K $\Omega$ ) | Rmax(K $\Omega$ ) | T (°C)               | Rmin(K $\Omega$ ) | Rnom(K $\Omega$ ) | Rmax(K $\Omega$ ) |              |
| 34                                     | 6.5976            | 6.6911            | 6.7852            | 71                   | 1.5177            | 1.5618            | 1.6070            |              |
| 35                                     | 6.3149            | 6.4071            | 6.5000            | 72                   | 1.4644            | 1.5074            | 1.5516            |              |
| 36                                     | 6.0458            | 6.1368            | 6.2285            | 73                   | 1.4130            | 1.4551            | 1.4983            |              |
| 37                                     | 5.7897            | 5.8793            | 5.9697            | 74                   | 1.3639            | 1.4050            | 1.4472            |              |
| 38                                     | 5.5459            | 5.6342            | 5.7233            | 75                   | 1.3168            | 1.3569            | 1.3981            |              |
| 39                                     | 5.3139            | 5.4007            | 5.4884            | 76                   | 1.2715            | 1.3107            | 1.3510            |              |
| 40                                     | 5.0929            | 5.1783            | 5.2646            | 77                   | 1.2280            | 1.2663            | 1.3057            |              |
| 41                                     | 4.8823            | 4.9663            | 5.0512            | 78                   | 1.1862            | 1.2236            | 1.2621            |              |
| 42                                     | 4.6818            | 4.7643            | 4.8478            | 79                   | 1.1460            | 1.1826            | 1.2202            |              |
| 43                                     | 4.4908            | 4.5718            | 4.6538            | 80                   | 1.1075            | 1.1432            | 1.1799            |              |
| 44                                     | 4.3087            | 4.3882            | 4.4687            | 81                   | 1.0704            | 1.1053            | 1.1412            |              |
| 45                                     | 4.1351            | 4.2131            | 4.2922            | 82                   | 1.0348            | 1.0689            | 1.1040            |              |
| 46                                     | 3.9696            | 4.0461            | 4.1237            | 83                   | 1.0005            | 1.0338            | 1.0681            |              |
| 47                                     | 3.8117            | 3.8868            | 3.9629            | 84                   | 0.9676            | 1.0001            | 1.0336            |              |
| 48                                     | 3.6612            | 3.7348            | 3.8095            | 85                   | 0.9359            | 0.9677            | 1.0005            |              |
| 49                                     | 3.5176            | 3.5897            | 3.6629            | 86                   | 0.9054            | 0.9365            | 0.9685            |              |
| 50                                     | 3.3805            | 3.4512            | 3.5230            | 87                   | 0.8760            | 0.9064            | 0.9377            |              |
| 51                                     | 3.2470            | 3.3162            | 3.3865            | 88                   | 0.8478            | 0.8775            | 0.9081            |              |
| 52                                     | 3.1195            | 3.1872            | 3.2561            | 89                   | 0.8207            | 0.8497            | 0.8796            |              |
| 53                                     | 2.9975            | 3.0638            | 3.1313            | 90                   | 0.7945            | 0.8228            | 0.8520            |              |
| 54                                     | 2.8810            | 2.9459            | 3.0119            | 91                   | 0.7693            | 0.7970            | 0.8256            |              |
| 55                                     | 2.7696            | 2.8331            | 2.8977            | 92                   | 0.7451            | 0.7721            | 0.8001            |              |
| 56                                     | 2.6631            | 2.7252            | 2.7885            | 93                   | 0.7217            | 0.7481            | 0.7754            |              |
| 57                                     | 2.5613            | 2.6220            | 2.6839            | 94                   | 0.6992            | 0.7250            | 0.7517            |              |
| 58                                     | 2.4639            | 2.5233            | 2.5839            | 95                   | 0.6774            | 0.7027            | 0.7288            |              |
| 59                                     | 2.3707            | 2.4288            | 2.4881            | 96                   | 0.6565            | 0.6812            | 0.7067            |              |
| 60                                     | 2.2815            | 2.3383            | 2.3963            | 97                   | 0.6363            | 0.6604            | 0.6854            |              |
| 61                                     | 2.1962            | 2.2517            | 2.3084            | 98                   | 0.6168            | 0.6404            | 0.6648            |              |
| 62                                     | 2.1144            | 2.1687            | 2.2241            | 99                   | 0.5980            | 0.6211            | 0.6450            |              |
| 63                                     | 2.0363            | 2.0893            | 2.1435            | 100                  | 0.5800            | 0.6025            | 0.6259            |              |
| 64                                     | 1.9614            | 2.0132            | 2.0662            | 101                  | 0.5625            | 0.5845            | 0.6073            |              |
| 65                                     | 1.8897            | 1.9403            | 1.9921            | 102                  | 0.5456            | 0.5672            | 0.5895            |              |
| 66                                     | 1.8209            | 1.8704            | 1.9210            | 103                  | 0.5293            | 0.5504            | 0.5723            |              |
| 67                                     | 1.7550            | 1.8034            | 1.8529            | 104                  | 0.5136            | 0.5342            | 0.5556            |              |
| 68                                     | 1.6919            | 1.7391            | 1.7875            | 105                  | 0.4984            | 0.5186            | 0.5395            |              |
| 69                                     | 1.6313            | 1.6775            | 1.7248            |                      |                   |                   |                   |              |
| 70                                     | 1.5733            | 1.6184            | 1.6646            |                      |                   |                   |                   |              |