

Instruction Manual

Solar Air Source Heat Pump water heater

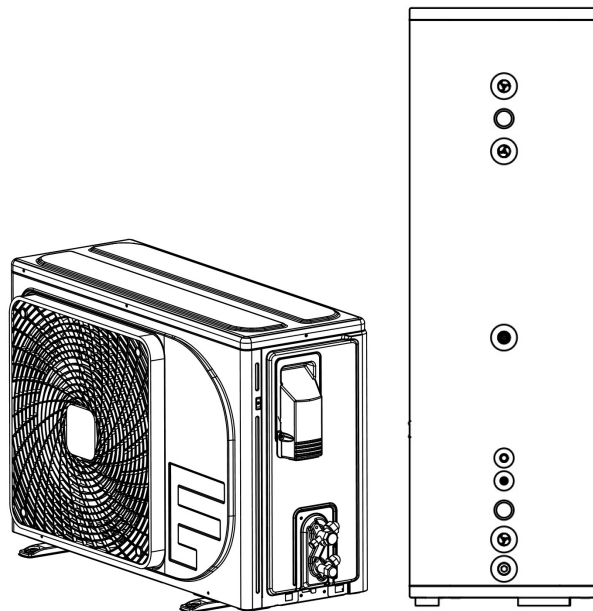
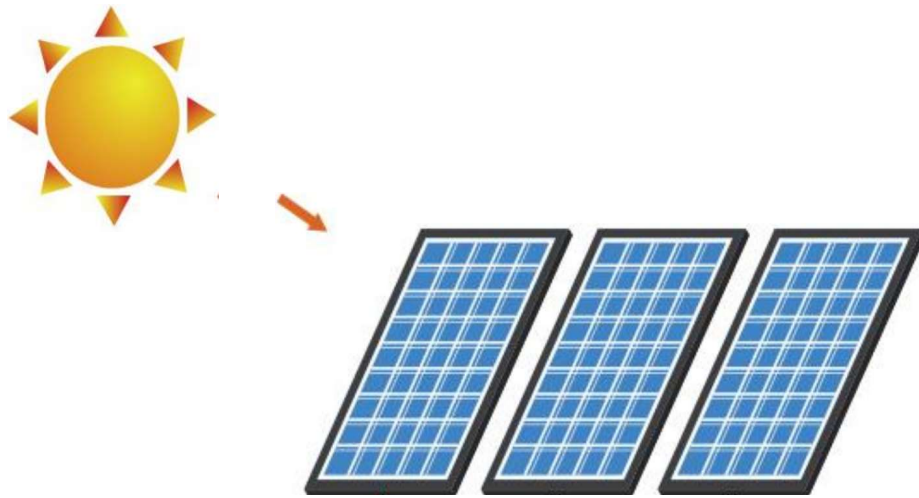

- Installation work should be done by professionals.
- For your convenience, please read this manual carefully and follow the steps in the manual.
- Please keep the manual properly for easy reference.

CONTENTS

1. Product Introduction.....	1
2. Specifications	2
3. Use and Operation Instruction of Wire Controller.....	3
3.1. Interface Display.....	3
3.2. Key and Icon Function Instruction	3
3.2.1 Key Function Instruction	3
3.2.2 Icon Function Instruction	4
3.2.3 Screen Display Description.....	5
3.3. Startup & Shutdown.....	5
3.4. Temperature Setting.....	5
3.5. Clock Setting.....	6
3.6. Setting of Timing ON/OFF	6
3.7. Power Limiting Function	9
3.8. Turbo Function	9
3.9. Keyboard Lock.....	10
3.10. Parameter Setting	10
3.11. Refrigerant Collection	11
3.12. Fault Interface	13
4. Installation Environment Requirements	14
5. Installation and Connection	16
6. Operating rules for Photovoltaic Panels.....	18
7. Debugging and Running	21
8. Safety Precautions.....	22
9. Non-fault Phenomenon.....	23
10. Common Faults and Solutions	24

1. Product Introduction

Air source heat pump water heater is driven by a small amount of electricity. Through the reverse Carnot cycle principle, it will be difficult to use the low grade heat energy in the air to improve the available high grade heat energy, used for heating water. It is a new generation of hot water making device following boiler, gas water heater, electric water heater and solar water heater.

Solar air source heat pump water heater adds solar photovoltaic power generation function on the basis of air source heat pump water heater. The direct current generated by solar energy is directly supplied to the unit so that hot water can be produced with only a small amount of electricity or without electricity. It has all the advantages of air source heat pump water heater, and its energy efficiency is higher. It is the real green, energy saving, environmental protection, comfortable and safe products.

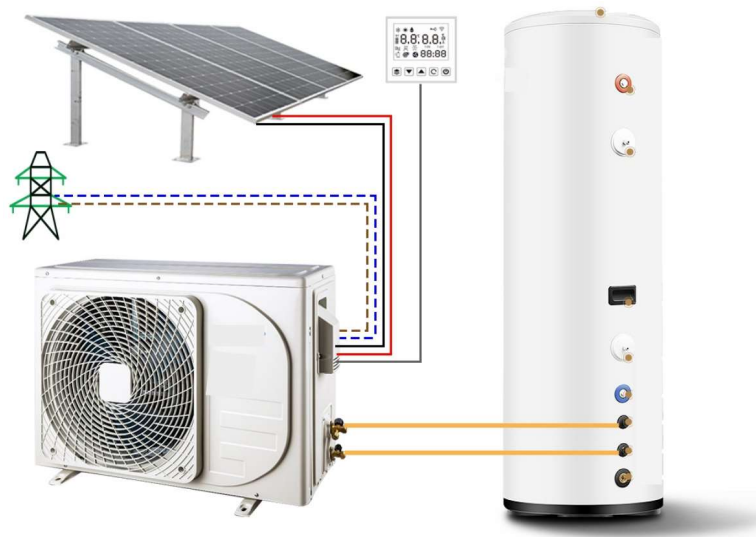

Solar air source heat pump water heater the following core characteristics:

- Safety
During operation, the unit will not discharge any waste water or waste gas, and water and electricity are completely separated. It fundamentally eliminates flammable, explosive, electric shock, dry burning, carbon monoxide poisoning and other safety hazards that may exist in ordinary water heaters, and protects the health and safety of family members.
- Power saving
Its operating COP value is as high as 4.0 (that is, 1 KWH of electricity consumption can generate heat equivalent to 4 KWH of electricity), and it is directly run by the solar photovoltaic power generating unit to heat water temperature during the day. It can use no electricity or only a small amount of electricity, so the use cost is very low.
- Rest assured.
Not only does the unit heat water quickly, but also the tank holds a large amount of water, which can meet the needs of the whole family. In addition, the thermal insulation effect of the water tank is good, so that users can use hot water at any time.

2. Specifications

Model		200L	300L
Rated Grid Power(AC)		208-240V 50-60HZ	
Solar Panel Power(DC)		80-380V	
Heating Capacity	W	3700	4100
Water Heating Capacity	L/h	79.5	88.1
COP	W/W	4.30	4.22
Rated Power Consumption	W	860	972
Rated Current	A	4.0	4.5
Max Power consumption	W	1300	1600
Max Current(AC)	A	6.0	7.4
Max Current(DC)	A	12.0	12.0
Water Proof Level		IPX4	
Electric Shock Prevention		Class I	
Refrigerant		R410A	
Compressor		Rotary	
Water Side Heat Exchanger		External micro-channels	
Air Side Heat Exchanger		Finned tube	
Fan Power Input	W	40	40
Water Tank rated volume	L	200	300
Number of Applicable Users	person	3~5	4~6
Max Water Pressure	Mpa	0.8	
Inlet/Outlet Connector Diameter	inch	G3/4"	
Noise Level	dB(A)	50	52
Connecting Pipe Diameter	inch	1/4"+3/8"	
Net/Gross Weight (Outdoor)	kg	33.5/37.5	
Net/Gross Weight (Tank)	kg	60/68	80/92
Dimension(Outdoor)	mm	802×564×323	
Dimension(Tank)	mm	Φ520×1600	Φ580×1820
Packing Dimension(Outdoor)	mm	910×622×405	
Packing Dimension(Tank)	mm	550×550×1665	605×605×1915
Rated Outlet Temperature	°C	55	
Safety Outlet Temperature	°C	60	
Operating Ambient Temperature	°C	-15~43	

Note:

1. Test condition: Ambient Temp.(DB/WB): 20°C/15°C, Water Temp.(Initial/Final): 15°C/55°C;
2. Parameters are subject to change without prior notice, please refer to the nameplate.

3. Use and Operation Instruction of Wire Controller

3.1. Interface Display

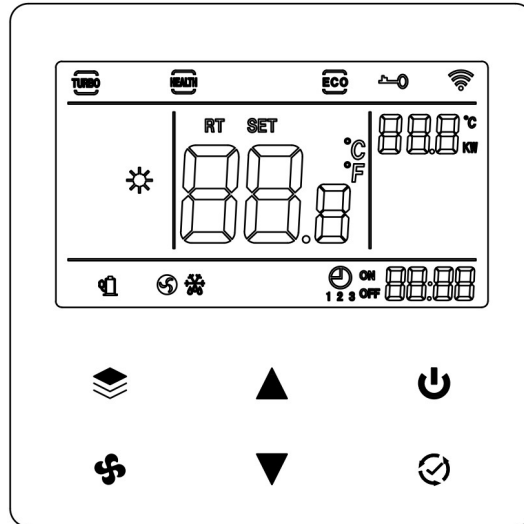

3.2. Key and Icon Function Instruction

3.2.1 Key Function Instruction

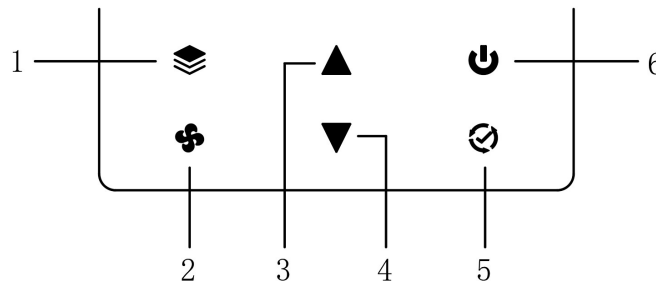

No.	Designation	Function
1	Setting key	<ul style="list-style-type: none"> ■ Short press to enter timing setting. ■ Long press for 5 seconds to enter the parameter setting screen.
2	Wind speed & time Settings key	<ul style="list-style-type: none"> ■ Short press to enter or quit turbo mode. (That is, the power limiting function is forcibly cancelled) ■ Short press for 5 seconds to enter the time setting. After the setting is completed, press the mode key to return to the main interface.
3	Up key	<ul style="list-style-type: none"> ■ It is used to increase or decrease variable value. ■ Long press to speed up the scrolling speed of time or parameters.
4	Down key	
5	On-off key	<ul style="list-style-type: none"> ■ Short press to turn on/off the unit.
6	Mode key	<ul style="list-style-type: none"> ■ Short press to switch mode. (There is only heating mode, so it cannot be switched)

3.2.2 Icon Function Instruction

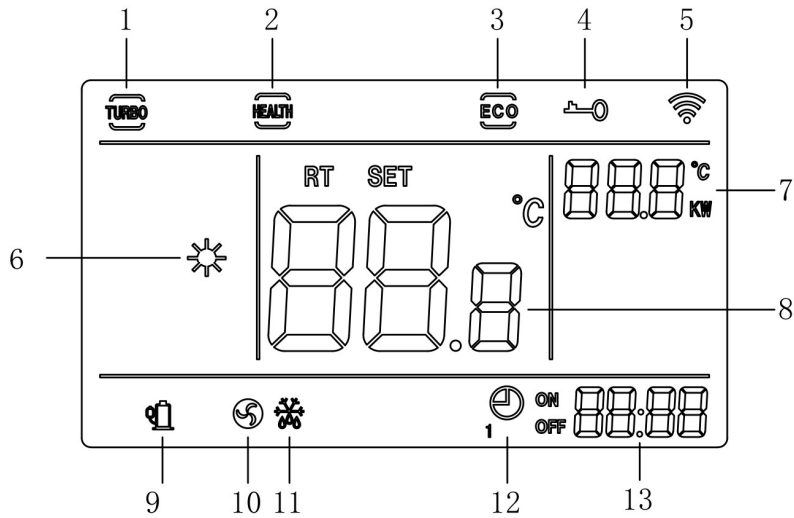

No.	Designation	Description
1	Turbo symbol	The unit operates at maximum load to achieve rapid heating or cooling effect.
2	Health symbol	It is used for the entry of refrigerant collection function.
3	Power limiting symbol	Limit the use of mains electricity and give priority to photovoltaic power. It will display when the power limiting function is enabled.
4	Keyboard lock symbol	Keep long press of “up” and “down” keys for 5 seconds to lock or unlock the keyboard.
5	WIFI symbol	It will display when the WIFI is successfully configured. (There is no WIFI function for the time being)
6	Heating symbol	It will display during heating.
7	Real-time tank temp.	The real-time water tank temperature displays, accuracy: 0.1℃
	Real-time power	The real-time grid power displays, unit: KW(According to the selection)
8	Setting temp.	During setting temperature adjustment, the setting temperature displays; otherwise, the real-time temperature displays.
9	Compressor operation symbol	This icon is displayed when the compressor is running. (Always on) This icon is not displayed when the compressor is shut down. After the refrigerant collection function is enabled, the icon blinks..
10	Fan operation symbol	This icon is displayed when the DC fan is running.
11	Defrosting symbol	It will display in the defrosting process of the unit.
12	Timing switch symbol	It will display when the timing function is enabled. When the timed boot function is enabled, ON is displayed When the timed shutdown is enabled, OFF is displayed.
13	Clock time	It displays the current time or timing time.

3.2.3 Screen Display Description

When the “KW” icon on the secondary screen of the wire controller is on, the real-time power display function is enabled; Otherwise, the real-time water temperature display function is displayed, and the “°C” icon is on.

1. Real-time power display function

When the “KW” icon on the secondary screen is lit up, the water temperature will be folded to the “RT” temperature value of the main screen for display. The real-time power is displayed as the AC input power (Unit: KW).

2. Water temperature display function

When the “°C” icon on the secondary screen is lit up, the real-time power display function is turned off, and real-time water temperature is fixed on the secondary screen. The "SET" icon is always displayed on the main screen, and the setting temperature value is fixed on the display.

Note: The switch display function has been set in factory and cannot be changed by users.

3.3. Startup & Shutdown



Short press “” to start the unit. In the startup state, the interface displays the setting temperature and other states; Short press “” again and the unit will stop running. In the shutdown state, the interface does not display the setting temperature.

Figure 1 and Figure 2 below correspond to the interface display in startup state and shutdown state respectively.

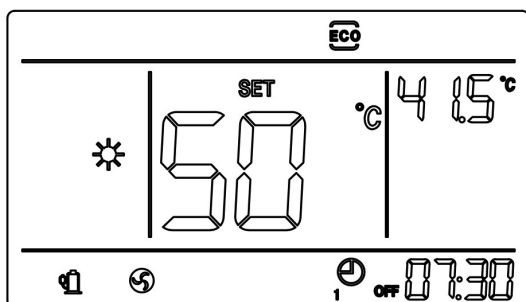

Figure 1. Startup status interface

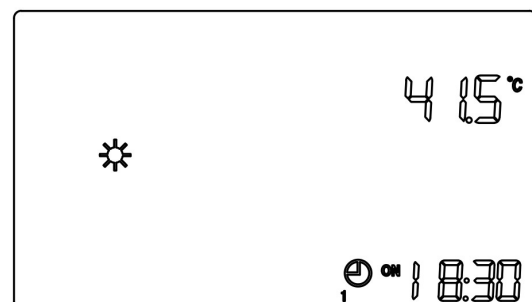



Figure 2. Shutdown status interface

3.4. Temperature Setting

In the startup state, press “” or “” to increase/decrease the water temperature setting value. (As shown in figure 3)

Note: Adjustable temperature range is 30~60°C. (The factory default value is 50°C)

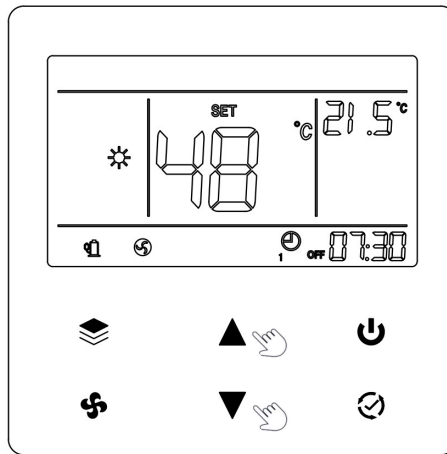

Figure 3. Operation diagram of temperature setting

3.5. Clock Setting

Setting steps:

1. After long pressing “☼” for 3 seconds, the time display module will blink at the frequency of 1 second and enter the clock setting state;
2. Long press or short press “▲” or “▼” to scroll to the current time point, such as 10:00 in Figure 4;
3. When the correct time is reached, press the “☑”. at this time, the time display module will stop flashing, and the time setting is completed.

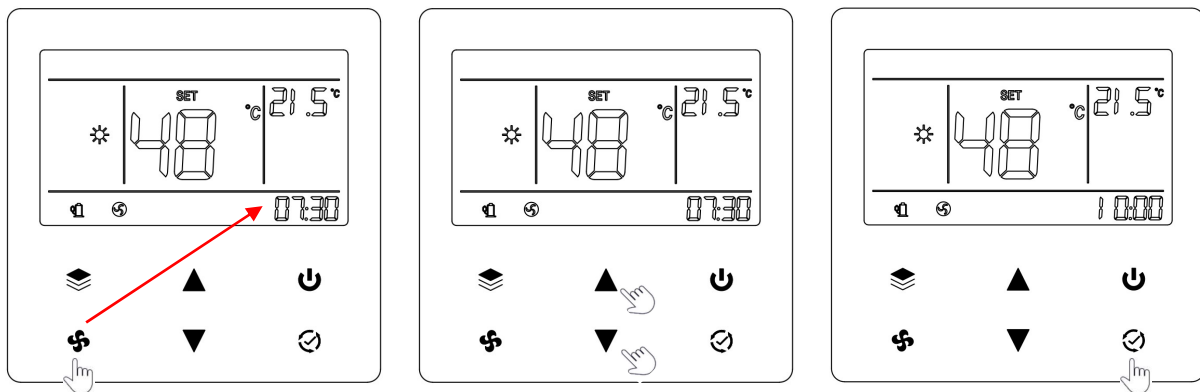

Figure 4. Operation diagram of clock setting

3.6. Setting of Timing ON/OFF

At present, the wire controller can realize the timing setting of 3 periods in one day. Users can set the opening or closing time as well as the opening and closing time for each period according to their own requirements. You are advised to set the timer after the clock setting is completed.

Setting steps:

1. Short press “☼” to enter the timing setting interface, and the timing period and timing status are displayed flashing. If you short press “☼” continuously, it will cycle between time period 1,

time period 2, time period 3, HEALTH, ECO and WIFI (As shown in Figure 5). In addition, in the time period, the nixie tube display “ON” indicates that the time period is enabled, and the display “OFF” indicates that the time period is not enabled.

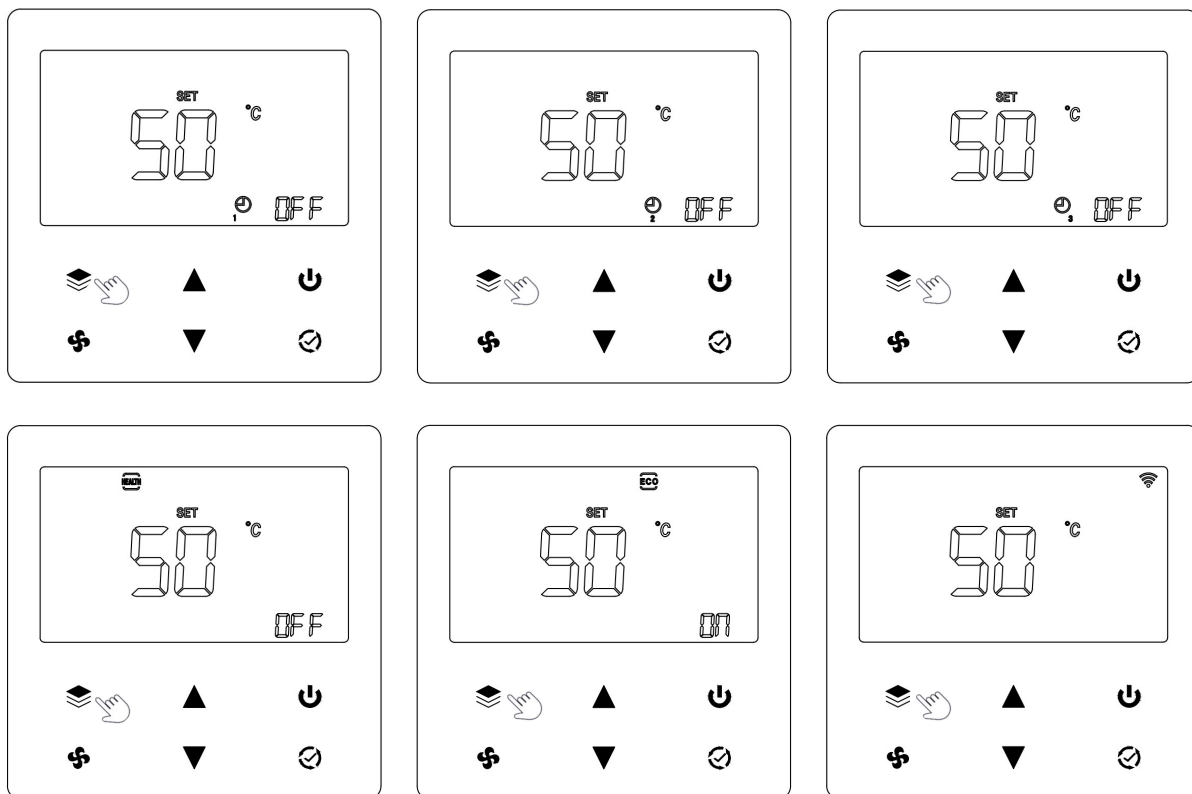

Figure 5. Function switching interface

2. After selecting a time period (for example, time period 1), short press “ ▲ ” or “ ▼ ” to enable or disable the timing. If you select “OFF”, the timing function is disabled. Otherwise, select “ON” to enable, as shown in Figure 6:

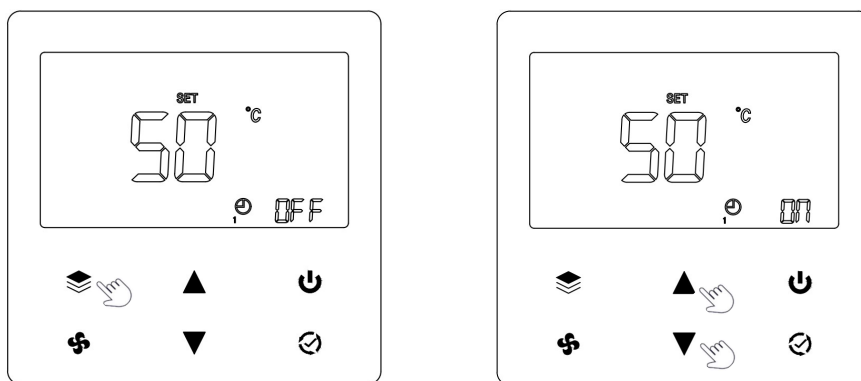

Figure 6. Enabling the timing of time period 1

3. After the timing is enabled (that is, the timing display is ON), press “ ✓ ” to enter the startup time setting with the time blinking (as shown on the left in Figure 7).
4. Set the startup time by pressing “ ▲ ” or “ ▼ ”, for example, set the startup time to 6:00. When the time is adjusted to 6 o'clock, press “ ✓ ” to complete the setting of startup time in period 1 (as shown on the right in Figure 7).

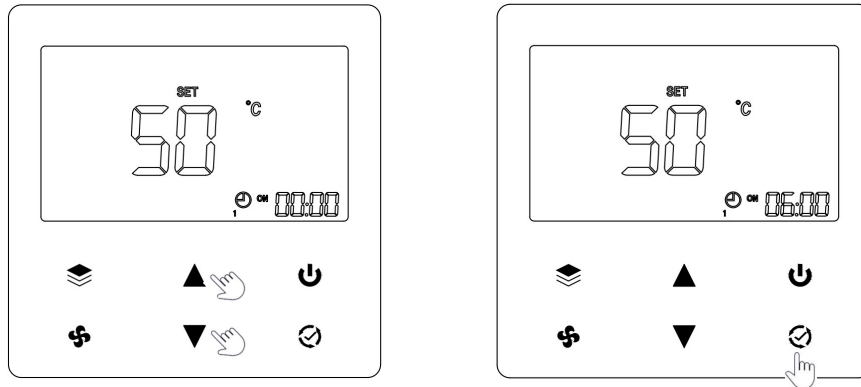

Figure 7. Setting of startup time for time period 1

5. After that, the interface will automatically jump to the shutdown time setting of period 1, and the shutdown time will blink (as shown on the left in Figure 8).
6. Under the setting state of regular shutdown time, press “▲” or “▼” to adjust the time, such as 23:00, then press “☑” to complete the setting of shutdown time in period 1 (as shown on the right in Figure 8). At this point, the timing setting of period 1 is completed.

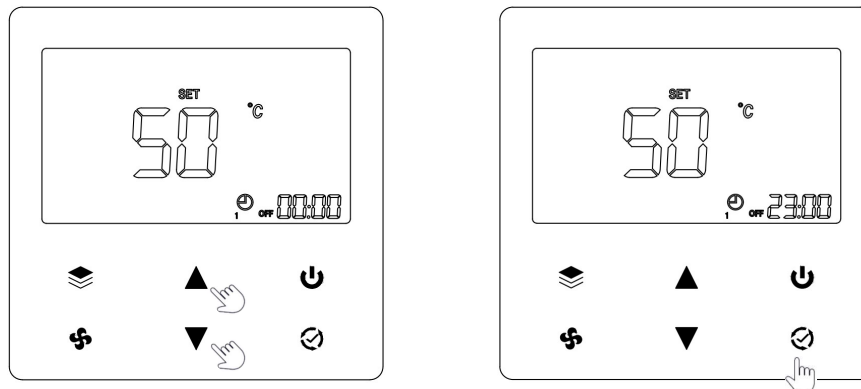

Figure 8. Setting of shutdown time for time period 1

7. After the timing setting of period 1 is completed, the scheduled time stops blinking and displays the scheduled task that will be executed first. If the current time is 10:00 and the unit is on, the unit shutdown task at 23:00 in period 1 will be executed first. Its display interface is shown in Figure 9.

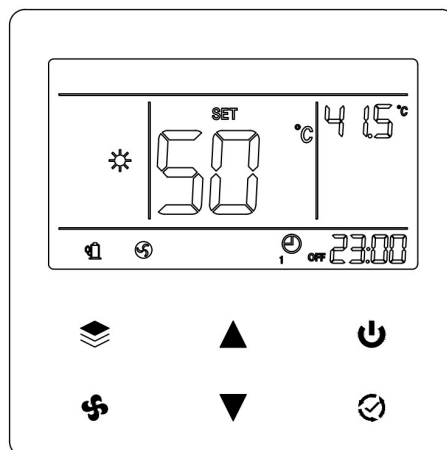

Figure 9. The most recent scheduled task at the current time

3.7. Power Limiting Function

The power limiting function is enabled by default at the factory. Photovoltaic power generation is used for heating during the day. At night or when there is no sunlight, the unit does not run, giving full play to the advantages of solar air source water heater.

When the hot water consumption is high or the lighting condition is poor, you can hold down “☼” and “▼” for 5 seconds at the same time to cancel the power limiting function, with the “ECO” icon going out. After canceling the energy saving function, the unit will quickly heat up according to the setting water temperature (when the photovoltaic power generation is insufficient, AC mains electricity will be consumed);

When you hold down “☼” and “▼” for 5 seconds again at the same time, the power limiting function will be enabled again, and the "ECO" icon will light up. (As shown in Figure 10)

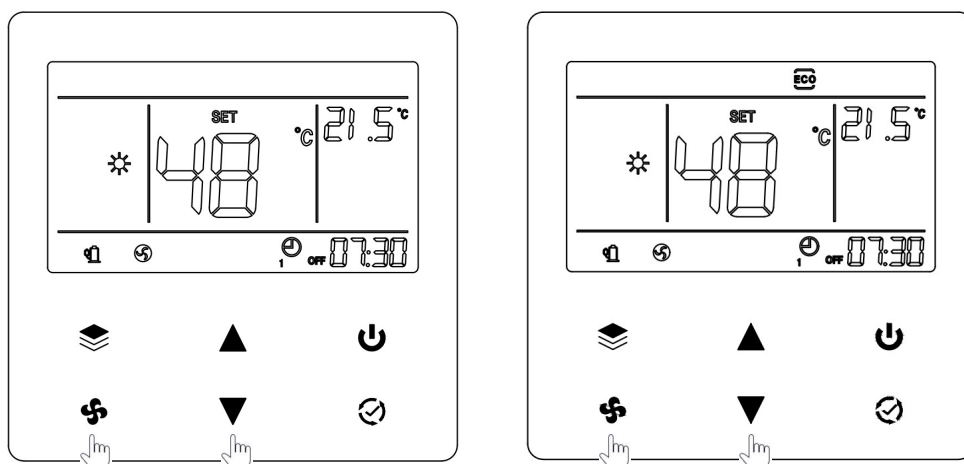

Figure 10. Operation of power limiting function from off to on

Note:

- The system automatically remembers the setting status after setting the power limiting function by combining keys.
- In addition to entering the power limiting function by pressing the combination button, you can also enter the power limiting function by setting parameters. When the parameter of power limiting function is set to “1”, the power limiting function cannot exit even if the combined key is disabled.
- In the power limiting state, you can exit it by pressing “☼”.

3.8. Turbo Function

In startup state, by short pressing “☼”, the "TURBO" icon lights up, and the power limiting function is forcibly cancelled. Then the unit heats up according to the maximum power. Short press “☼” again and the "TURBO" icon will go out.

After reaching the setting water temperature, or the unit is shut down, or the unit is shut down due to malfunction. the turbo mode will exit automatically.

3.9. Keyboard Lock

To avoid others' misoperation, please lock the wire controller after completing the setting. Keep long press of “▲” and “▼” keys for 5 seconds to lock or unlock the keyboard.

Notes: Under the locked screen interface, only unlocking operation is available.

3.10. Parameter Setting

The user can query and set the parameters of the unit through the wire controller.

The parameters available for users to set are shown in the following table:

Parameter No.	Parameter	Default value	Adjustable range	Note
32	Power limiting function	0	0-1	0: the power limiting function is disabled 1: the power limiting function is enabled

Setting steps:

1. Enter the parameter setting screen

After long pressing “≡” for 5 seconds, the screen will enter the parameter query & setting interface, as shown in Figure 11.

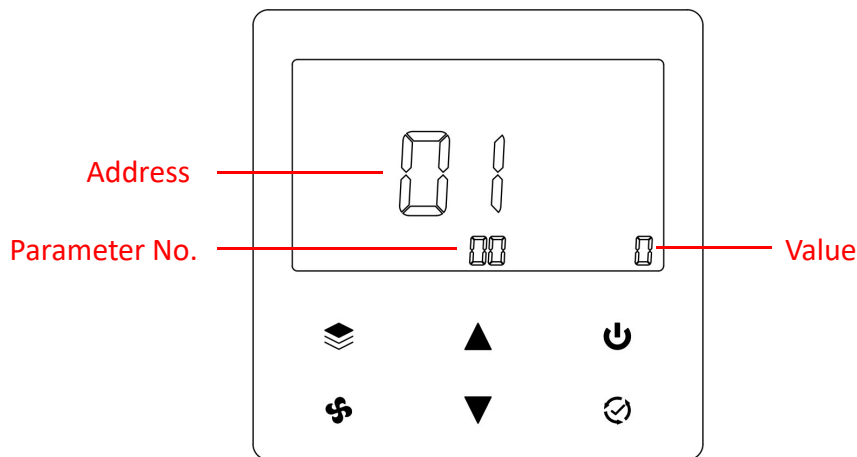

Figure 11. Parameter setting interface and the meaning of each value

2. Change the parameter Serial Number

Adjust it to the serial number to be changed by pressing “▲” or “▼”. (As shown on the left in Figure 11)

3. Change the parameter Value

Hold down “≡” for 5 seconds after the target parameter serial number is selected, then the value starts flashing. Adjust the parameter to the required value by short pressing “▲” or “▼”. press “≡” to confirm the change.

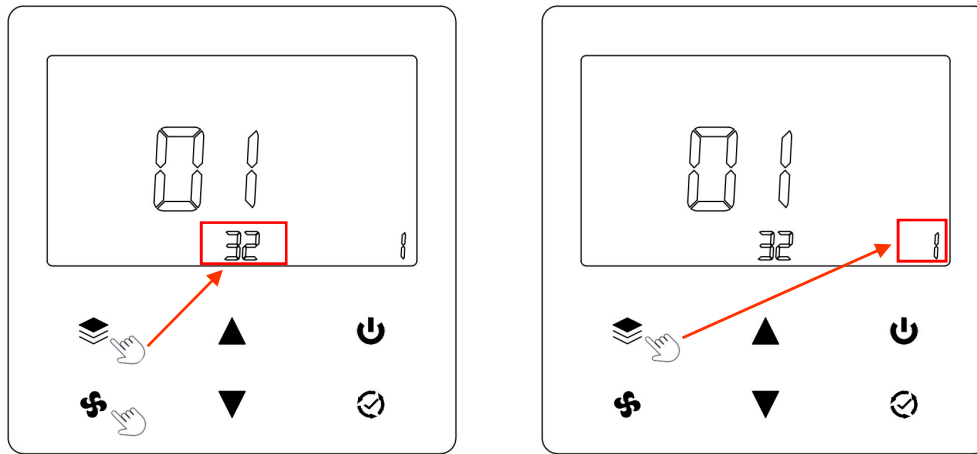

Figure 12. Parameter setting operation interface

4. Confirm parameter Settings

After all parameters are adjusted, press “☑” to exit the parameter change interface.

⚠ ATTENTION:

As the modification of parameters is related to the stable operation of the unit, please hand it over to professional maintenance personnel or operate it under the guidance of maintenance personnel.

3.11. Refrigerant Collection

Steps:

1. In startup state, the health function setting screen is displayed after selecting the "HEALTH" by pressing “☰” several times. The "HEALTH" icon and its corresponding parameter "OFF" are blinking simultaneously. Change "OFF" to "ON" by pressing “▲” or “▼”. Then press “☑” to confirm the change.
2. If you press “▲” or “▼” more than eight times within 5 seconds, the refrigerant collection function will be enabled, and the compressor icon start to blink.
3. After the refrigerant is recovered, short press “⏻” to disable the refrigerant collection function.

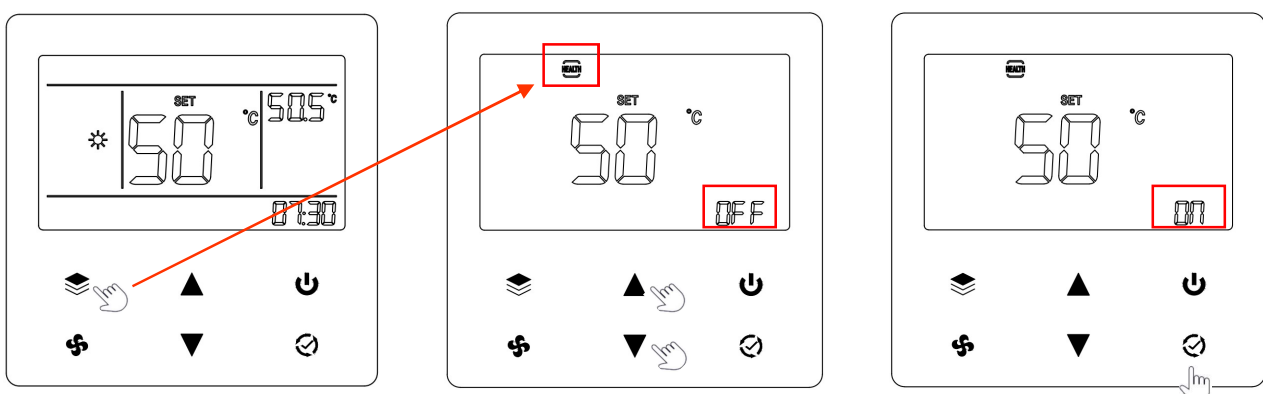

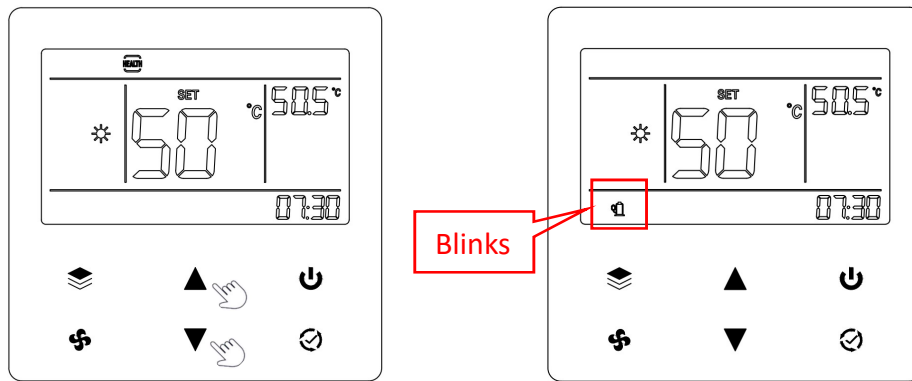

Figure 13. Refrigerant recovery operation interface

Note:

- Every time the temperature value changes, the count of key operation increases by one. If the temperature does not change, the count will not be counted.
- The change of temperature is only counted as the key operation, and does not change the original set value.

3.12. Fault Interface

When the unit fails, the current fault code will be displayed on the LCD screen of of the wire controller according to the fault reason if the fault lasts for 10 seconds. In addition, when the wire controller itself has problems, such as communication problems, the LCD screen will flash "888". If the unit cannot run normally due to a fault, contact professional maintenance personnel in time. Figure 11 shows the fault code for H4.

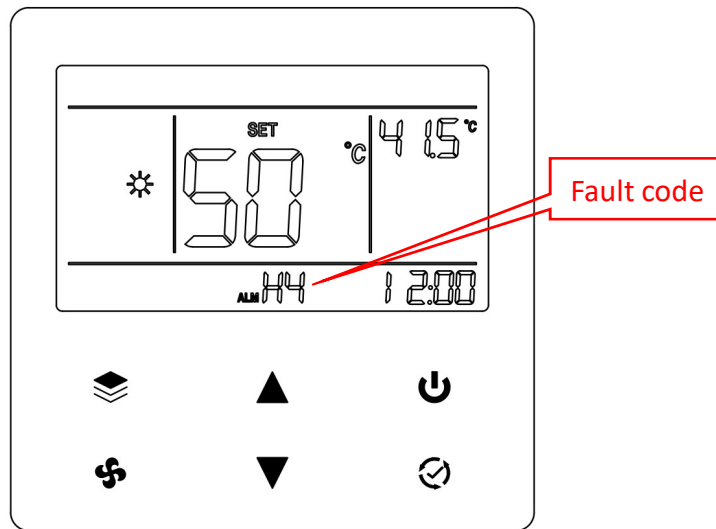

Figure14. Fault display interface

The following is a list of unit fault codes:

Protect/fault	Code	Note
Incorrect outdoor parameters	05	
High pressure protect	H4	
Low pressure protect	H5	
Water temp. sensor fault	J1	
Inner coil temp. sensor fault	J2	
Ambient temp. sensor fault	J5	
External coil temp. sensor fault	J6	
Discharge temp. sensor fault	J7	
Compressor feedback error	L5	
Refrigerant leakage fault	L7	Reserved
Outdoor DC fan fault	L8	
Input current control fault	73	
Overvoltage/Undervoltage protect	76	Reserved
Compressor stalled failure	93	
IPM Overcurrent	95	

4. Installation Environment Requirements

❑ Outdoor unit

- ◆ The outdoor unit can be installed on external walls, roofs, balconies or floors. Its installation must be firm, and must not arbitrarily change the building bearing structure, so as not to affect the safety of the building. (It is recommended to install the outdoor unit on the wall of brick structure);
- ◆ The distance between the outdoor unit and the water tank shall not be more than 3 meters, for the length of the connecting pipe is limited;
- ◆ The installation position of the external machine should be well ventilated to ensure that the inlet and outlet are unimpeded, as shown below:

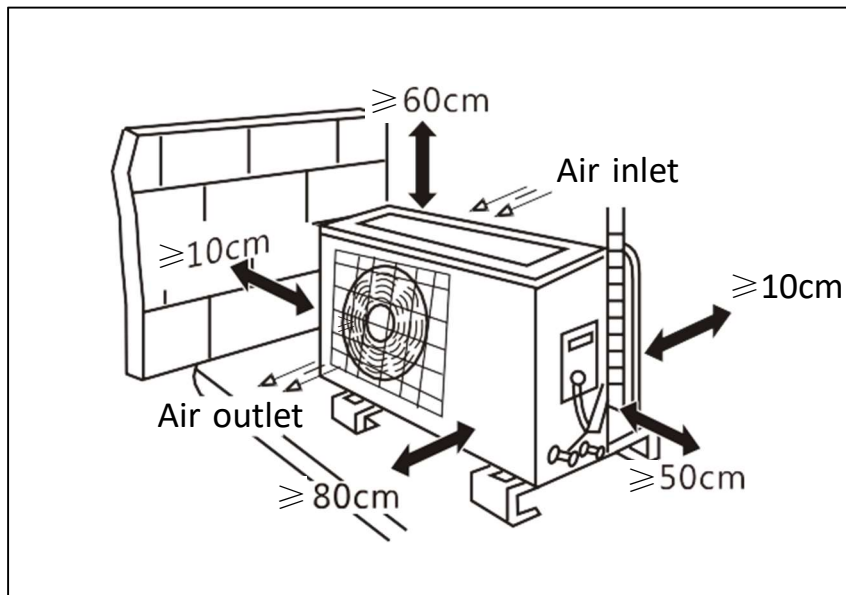

- ◆ Ensure that the unit is installed upright and not tilted to prevent noise;
- ◆ Condensate application pipes flow into drains or dedicated containers along building drains.

❑ Water tank

- ◆ The water tank must be installed vertically, and the site foundation must be solid and firm, and no pollution, corrosive substances;
- ◆ There should be water pipe and hot water pipe interface near the water tank;
- ◆ A drainage ditch or outlet should be set near the installation position of the water tank to facilitate drainage;

- ◆ It is recommended to install it in a non-indoor position (such as outdoor balcony). The water tank should be avoided as far as possible to install into the decorative wall or cabinet body, so as not to carry out maintenance.

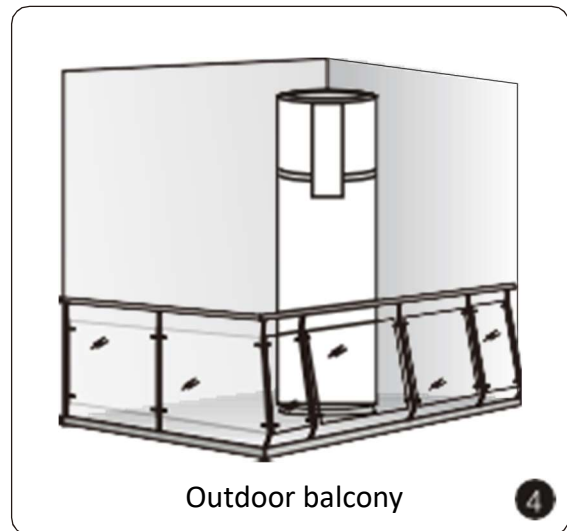
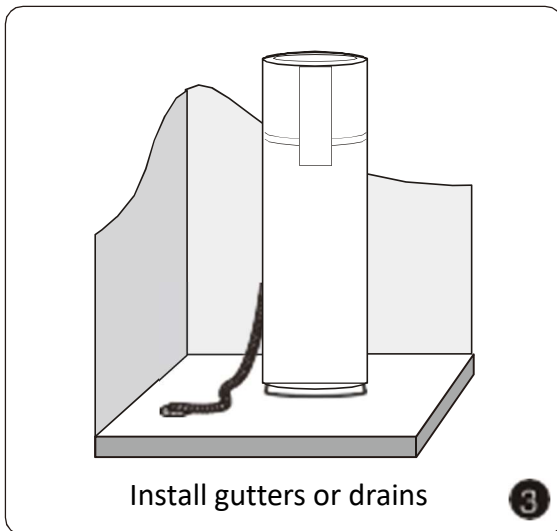
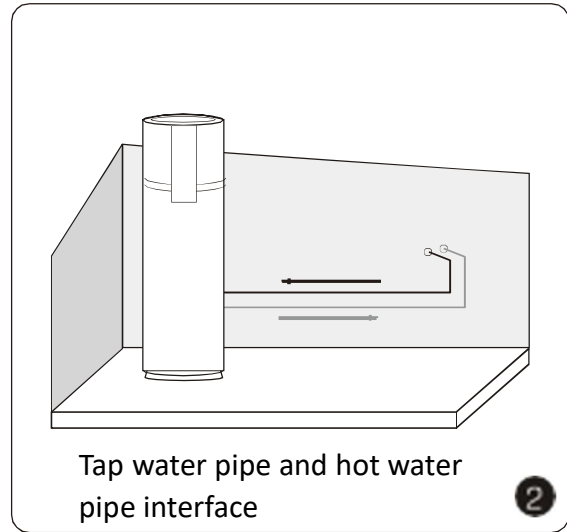
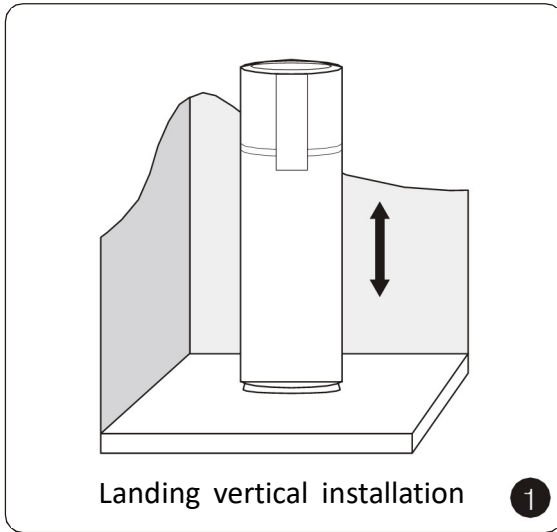

- ◆ The water quality of the air source heat pump heater should meet the following standards:

PH value	total hardness	electric conductivity	Sulfur ion	Chloride ion	Ammonium
6.5-8.0	<50ppm	<200uV/cm(25°C)	None	<50ppm	None
sulfate ion	silicon	iron content	Sodium ion	calcium ion	calcium ion
<50ppm	<30ppm	<0.3ppm	no requirement	<50ppm	

⚠ Warning:

For groundwater, well water, river water, sea water, industrial water or other water resources, the water system must be purified, otherwise, the resulting problems of the unit are not covered by the warranty.

5. Installation and Connection

The piping connection diagram of the water heater is shown as follows:

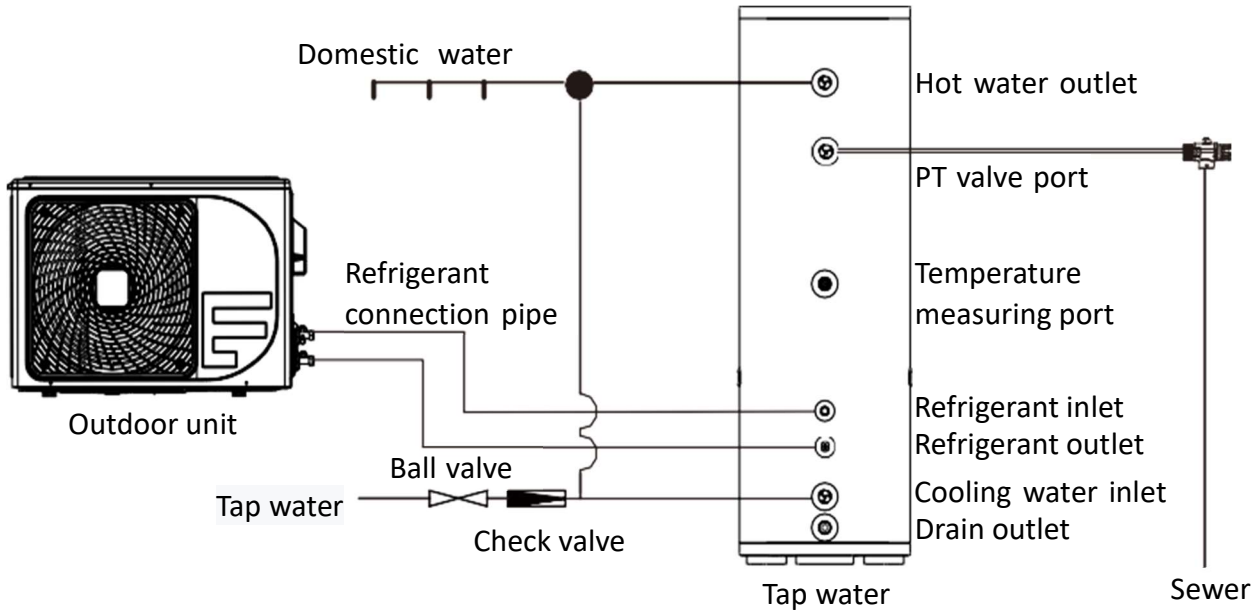

Note: According to the actual situation of the installation site and the installation requirements of the external machine and water tank, select an appropriate installation position and locate the water tank and the external machine.

- ❑ Install through-wall pipe (depending on actual situation)

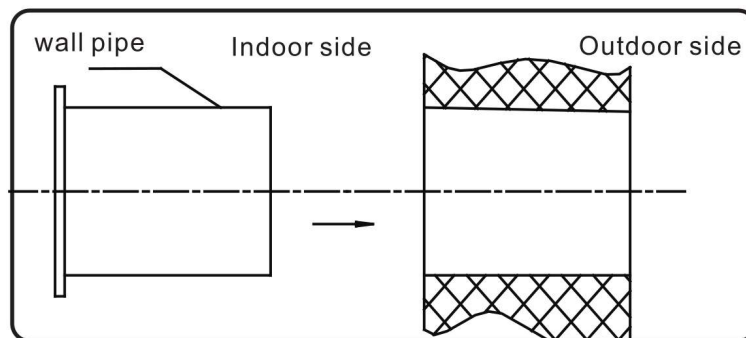

- ◆ According to the relative position of the outdoor unit and the water tank and the pipeline direction of the water pipe, determine the position of drilling on the wall;
- ◆ The wall hole should be selected in the most conducive to the installation of the unit or water pipe position, while considering the overall appearance of the room;
- ◆ Before drilling holes in walls, ceilings, and floors, check whether cables or pipes are buried. If any, avoid them.

❑ Refrigerant pipe connection

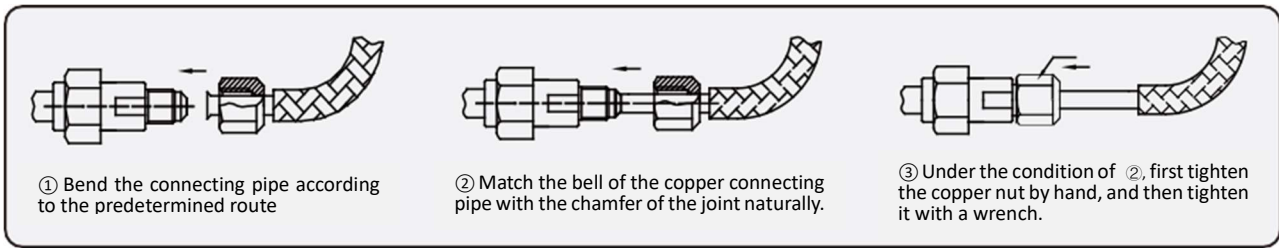

- ◆ First of all, expand the connecting pipe, and slowly expand the connecting pipe a small section at a time, without yanking the connecting pipe;
- ◆ Bend the connecting pipe according to the predetermined route, bending radius is greater than 100mm;
- ◆ Connect the unit and the water tank with a flared joint, drop a small amount of frozen oil in the flared joint, and then tighten it;
- ◆ Loosen the big valve connecting nut two circles, and then open the small valve with an inner hexagon wrench. When the refrigerant flows into the water tank from the outdoor unit, the air in the copper tube of the heat pump water tank is discharged. When the temperature of the exhaust gas becomes low, tighten the big valve connecting nut;
- ◆ Open the large and small valves to the maximum opening with an inner hexagon wrench;
- ◆ Check the copper pipe connection with soap bubbles. After confirming that there is no leakage, heat the copper pipe connection with a thermal insulation pipe to prevent heat loss.

❑ Electrical wiring

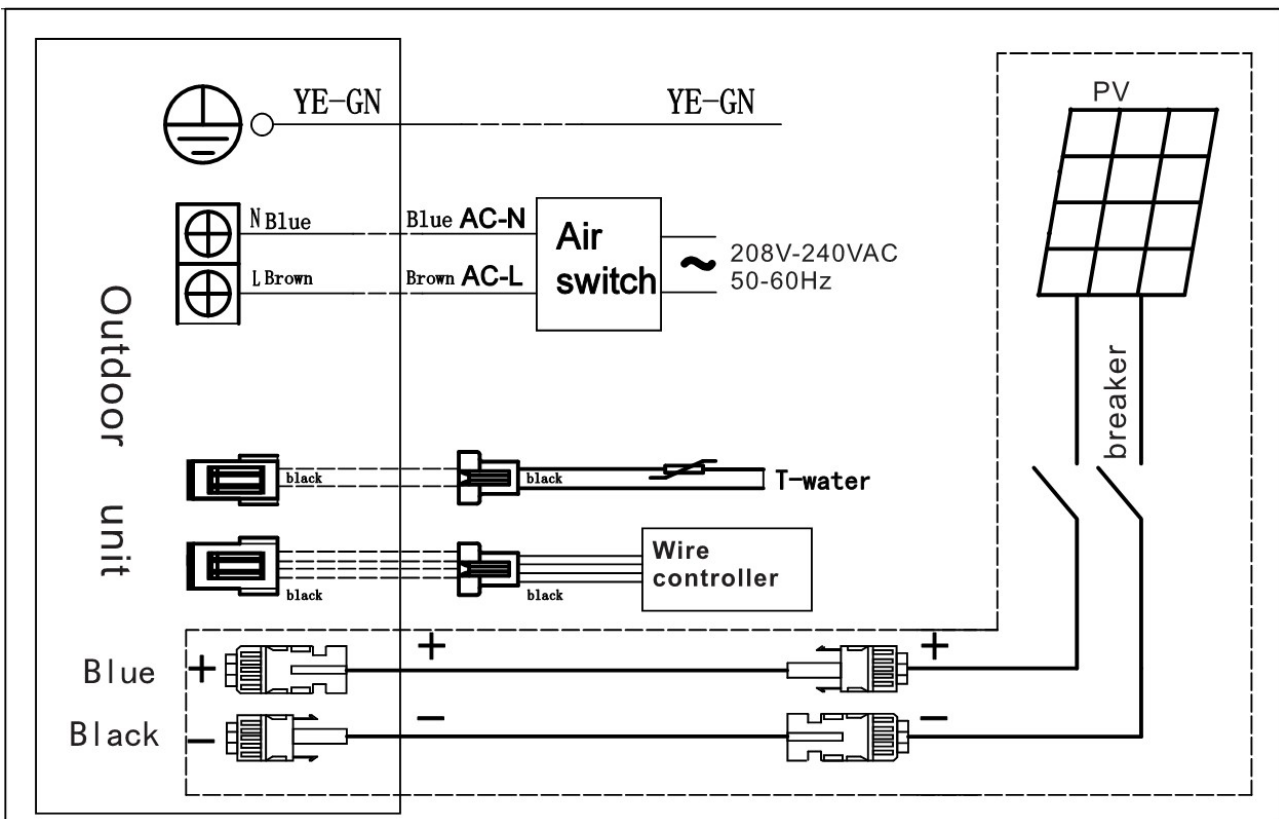

Note: if there is any change due to product improvement, the unit's internal label shall prevail.

6. Operating rules for Photovoltaic Panels

1. Disclaimer

With the update of Volta technology, the relevant information of the existing manual will be improved without notice. This manual is only for land installation, users and installers. should carefully read and abide by it.

2. General safety rules

- The installation of solar photovoltaic power generation system requires specialized skills and knowledge, which must be completed by a professionally qualified engineer.
- When the installer tries to install, operate and maintain the photovoltaic modules, please make sure that you fully understand the information in this installation instruction manual and understand the risk of injury that may occur during the installation process.
- Photovoltaic modules produce electricity when there is sufficient sunlight or other light sources. When operating, please take corresponding protective measures to avoid direct contact with 30VDC or higher voltage.
- Solar photovoltaic modules can convert light energy into direct current electricity, and the amount of electricity will change with the change of light intensity.
- When the component has current or has an external power supply, the component must not be connected or disconnected.
- When installing, using modules or wiring, opaque materials should be used to cover the front of the modules in the solar photovoltaic module array to stop power generation.
- All local, regional and national laws and regulations shall be complied with, and construction permits shall be obtained first if necessary.
- There are no user-repairable originals for solar photovoltaic modules. Do not disassemble, move or modify any attached parts.
- Do not wear metal rings, watch straps, earrings, nose rings, lip rings or other metal accessories when installing solar photovoltaic modules.
- Please do not install or operate the module when it is humid or windy.
- Do not use or install damaged components, and do not artificially condense light on the components.
- Only PV modules of the same model can be combined together. Avoid uneven shadows on the surface of photovoltaic modules. The shaded cells can become hot (the "hot spot" effect), which can cause permanent damage to the components.
- When an accident occurs, please turn off the isolating switch immediately.
- Defective or damaged components may still emit electricity. If you need to transport, please take measures to cover to ensure that the components are completely shaded.
- Keep children away from the module when transporting and installing the module.
- Please keep the photovoltaic modules in the original packing box before installation.

3. Select location

- The location where the module is installed should not be shaded or blocked all year round, and have sufficient sunlight.
- Solar photovoltaic modules generate electricity by light, please choose an appropriate installation angle to ensure that the modules can get the maximum amount of sunlight.

- The selection of module location should meet the requirements of various electrical and fire protection codes.
- Choosing a bracket
 - 1) The instructions and safety rules attached to the bracket should be followed.
 - 2) When the components leave the factory, the design has been completed. Please do not try to change the component structure or construction, etc.
 - 3) For standard installation, use the four symmetrical mounting holes on the inner side of the frame to fix the module on the bracket.
 - 4) The bracket and other required materials (such as bolts, etc.) should be made of durable, anti-corrosion, and anti-ultraviolet materials.
- Land installation
 - 1) When installing on the ground, choose a suitable installation height to prevent the lower part of the module from being covered by snow for a long time when it snows in winter. In addition, make sure that the lowest part of the module is high enough to avoid being blocked by plants or trees or being damaged by blowing sand.
 - 2) Check the building codes used during roof installation to ensure that the building and its structure (roof, exterior, load-bearing, etc.) to be installed have sufficient bearing capacity. When installing modules, make sure that the modules are installed on a fire-proof roof, and the roof inclination angle is less than 5in/ft, to ensure its fireproof level.
 - 3) When the module is installed on the roof or building, make sure that it is securely fixed and will not be damaged by strong wind or heavy snow.
 - 4) Ensure smooth ventilation on the back of the module (the minimum distance between the module and the mounting surface is 10cm).
 - 5) When installing on the roof, the roof that needs to be penetrated when installing the fixed components should be properly sealed to prevent leakage.

4. Installation Guide

- The components and supporting structure should be fixed with bolts through the mounting holes, which are only located at the rear flange position of the frame. No additional drilling is required.
- Use appropriate anti-corrosion fastening materials.
- There are many different ways to tighten up or down, and the installation method depends on the installation structure.
- The installation design should be checked by a professional engineer. Installation design and procedures should comply with local regulations and all legal functions.
- A torque wrench should be used during installation

5. Electrical installation

In some cases, the current or voltage generated by the component may be greater than the optimal operating current or voltage under its standard test conditions (STC). Therefore, when determining the original rating and load value, the open circuit voltage and open circuit current of the component under STC should be multiplied by 1.25. When determining the appropriate wire and fuse, the short-circuit current should be multiplied by 1.25 in accordance with Section 690-8 of the USNEC.

Electrical installation details:

- Components with the same configuration should be used on the same photovoltaic power generation system.
- If photovoltaic modules are connected in series, the total voltage is equal to the sum of the voltage of each module.
- If PV modules are connected in parallel, the total current is equal to the sum of the current of each module.
- Components provide prefabricated connectors for electrical connection of the system.
- The cross-sectional area and connector capacity of the selected cables should meet the maximum short-circuit current of the system.
- Install the components with one end with a junction box on the back facing upwards.
- Loop should be avoided when designing the system.
- Check whether the wiring is correct before starting.
- Ensure that the connection is secure and tight, and the plug shall not bear external pressure. It can only be used to connect the line, and shall not be used to open or close the circuit.
- Components and component support shall be properly grounded. Use the recommended connection terminals and connect the ground cable properly.
- You are advised to use a ground cable accessory (wiring nose) to connect the ground cable.
- All contacts in conducting connections shall be secured. Ferrous metals used in conductive connections should be treated with corrosion protection to prevent rust.

6. Maintenance

- Clean the glass surface of the component if it is dirty. Clean with a soft sponge dipped in water.
- Perform mechanical and electrical inspection every 6 months to ensure that the components are clean and connected reliably.
- If there is any doubt, please have qualified personnel check.
- Observe the maintenance instructions for all components used in the system, such as bracket, charging rectifier, inverter, battery, etc.
- If there is snow, use a brush with soft bristles to clean the surface of the component.

7. Recommended amount of photovoltaic panels

Model	Connection of photovoltaic panels	Recommended amount
200L		(280-360W) 4 pcs (360-450W) 3 pcs
300L		(280-360W) 5 pcs (360-450W) 4 pcs

7. Debugging and Running

- ◆ For the first time, make sure that the water tank has been filled up before plugging in the power supply.

⚠ Caution:

Operation steps of filling with water: Firstly, open the tap water inlet valve; Secondly turn on any hot water faucet in the hot water pipeline, and start filling until the hot water faucet overflows.

- ◆ Commissioning of the unit must be operated by professional personnel!
- ◆ The overall trial operation can be carried out when the whole system is checked and confirmed to meet the requirements.
- ◆ Switch on the power and turn on the air source water heater.
- ◆ Check whether the unit operation meets the requirements.

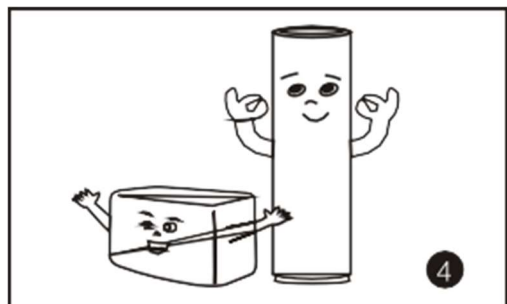
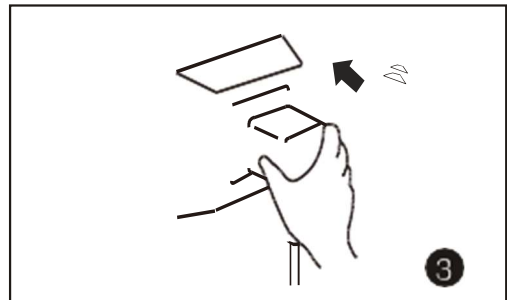
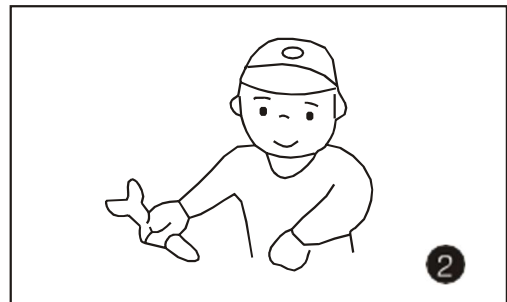
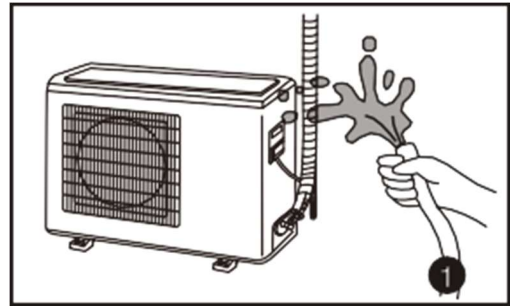

8. Safety Precautions



Caution & Warning

- ◆ Improper use may result in personal injury or damage to the unit, and in some cases, serious consequences.
- ◆ Please be responsible for the installation of the unit, if the unit is improperly installed, it may cause electric shock.
- ◆ If any abnormality occurs, cut off the power supply immediately and contact the seller for troubleshooting.
- ◆ Please do not put your hands or metal sticks into the unit.
- ◆ For maintenance and repair, please contact the dealer.
- ◆ Do not clean the unit directly with water. The unit must be cleaned by professional personnel, and the power supply must be cut off before cleaning.
- ◆ When connecting ground cables, do not connect them to gas pipes, waterways, lightning rods, or telephone ground cables.
- ◆ Leakage circuit breakers must be installed. Otherwise, it is easy to get an electric shock.
- ◆ If the power cord is damaged, a special power cord must be purchased from the distributor to replace it.
- ◆ If the compressor needs to be replaced during maintenance, the filter dryer must be replaced at the same time.
- ◆ Check the power supply and cable connection often. Should the unit begin to operate abnormally, switch it off and contact the qualified technician.

9. Non-fault Phenomenon

The following phenomena are normal performance of water heater, there is no need to worry about:

- ◆ When the power is switched on and the switch is turned on, the unit does not start immediately. This is because there is 3-minute delay protection, after 3 minutes, the unit will work normally.
- ◆ There is condensate discharge from the bottom of the unit after working for a period of time,, especially in the humid air environment.
- ◆ When the main engine is operating, you may hear a low running sound or "hiss" sound, which is the sound of refrigerant flowing.
- ◆ A small amount of water will be discharged from the relief port of the relief valve when the pressure of the water tank exceeds the unloading pressure of the relief valve.

10. Common Faults and Solutions

The unit is running, but the water temperature does not rise.

- ★ The fan is running but the compressor is not - check the compressor wiring.
- ★ Refrigerant leakage - Check refrigerant pipeline and add refrigerant after repair.
- ★ Thick frost accumulation in evaporator in winter - check the defrosting function, check whether the air duct is blocked, and check whether the system leaks.

Control panel does not display

- ★ Check whether the power indicator light of leakage protection plug is off - press the reset button and the power indicator light is on, indicating that the host is powered on.
- ★ Signal line disconnection - Check the signal line.
- ★ Signal cable short circuit due to damp, or poor contact - pull out the connection terminal, dry with a hair dryer and then plug again.

High noise of outdoor unit

- ★ Fastening screws loose -- retighten.
- ★ Copper pipe shake leads to collision of housing - adjust pipeline.

Safety valve leakage

- ★ Leakage at inlet or outlet of valve body - tighten inlet/outlet thread.
- ★ Leakage at discharge pressure relief outlet - check whether tap water pressure is too high and install pressure reducing valve if necessary.

